

A  
B  
C

# TF

## SECTION

# TRANSFER

TF

## CONTENTS

<b>SERVICE INFORMATION</b> .....		E
<b>DTC INDEX</b> .....		
C1201-C1210, U1000 .....		
<b>PRECAUTIONS</b> .....		
Precaution for Supplemental Restraint System (SRS) "AIR BAG" and "SEAT BELT PRE-TENSIONER" .....		
Precaution .....		
Service Notice or Precaution .....		
<b>PREPARATION</b> .....		
Special Service Tool .....		
Commercial Service Tool .....		
<b>NOISE, VIBRATION AND HARSHNESS (NVH) TROUBLESHOOTING</b> .....		
NVH Troubleshooting Chart .....		
<b>TRANSFER FLUID</b> .....		
Replacement .....		
Inspection .....		
<b>AWD SYSTEM</b> .....		
Power Transfer Diagram .....		
System Description .....		
Schematic .....		
CAN Communication .....		
<b>TROUBLE DIAGNOSIS</b> .....		
Fail-Safe Function .....		
How to Perform Trouble Diagnosis .....		
Location of Electrical Parts .....		
Circuit Diagram .....		
Wiring Diagram - AWD - .....		
Trouble Diagnosis Chart by Symptom .....		
AWD Control Unit Input/Output Signal Reference Value .....		
CONSULT-III Function (ALL MODE AWD/4WD) .....		
<b>TROUBLE DIAGNOSIS FOR SYSTEM</b> .....		
Power Supply Circuit for AWD Control Unit .....		
AWD Control Unit .....		
ABS System .....		
AWD Solenoid .....		
AWD Actuator Relay .....		
Engine Control Signal .....		
CAN Communication Line .....		
<b>TROUBLE DIAGNOSIS FOR SYMPTOMS</b> .....		
AWD Warning Lamp Does Not Turn ON When the Ignition Switch Is Turned to ON .....		
AWD Warning Lamp Does Not Turn OFF Several Seconds after Engine Started .....		
Heavy Tight-Corner Braking Symptom Occurs When the Vehicle Is Driven and the Steering Wheel Is Turned Fully to Either Side after the Engine Is Started .....		
Vehicle Does Not Enter AWD Mode Even Though AWD Warning Lamp Turned to OFF .....		
While Driving, AWD Warning Lamp Flashes Rapidly (When Flashing in Approx. 1 Minute and Then Turning OFF) .....		
While Driving, AWD Warning Lamp Flashes Slowly (When Continuing to Flash until Turning Ignition Switch OFF) .....		
<b>AWD CONTROL UNIT</b> .....		
Removal and Installation .....		
<b>FRONT OIL SEAL</b> .....		
Removal and Installation .....		
<b>REAR OIL SEAL</b> .....		
Removal and Installation .....		
<b>AIR BREATHER HOSE</b> .....		
Removal and Installation .....		
<b>TRANSFER ASSEMBLY</b> .....		
Removal and Installation .....		
Disassembly and Assembly .....		

---

**SERVICE DATA AND SPECIFICATIONS**  
**(SDS) ..... 57**

General Specification ..... 57

# DTC INDEX

< SERVICE INFORMATION >

## SERVICE INFORMATION

### DTC INDEX

C1201-C1210, U1000

INFOID:000000003275968

DTC	Items (CONSULT-III screen terms)	Reference
C1201	CONTROLLER FAILURE	<a href="#">TF-26, "AWD Control Unit"</a>
C1203	ABS SYSTEM	<a href="#">TF-26, "ABS System"</a>
C1204	4WD SOLENOID	<a href="#">TF-27, "AWD Solenoid"</a>
C1205	4WD ACTUATOR RLY	<a href="#">TF-28, "AWD Actuator Relay"</a> or <a href="#">TF-27, "AWD Solenoid"</a>
C1210	ENGINE SIGNAL 1	<a href="#">TF-29, "Engine Control Signal"</a>
U1000	CAN COMM CIRCUIT	<a href="#">TF-30, "CAN Communication Line"</a>

A  
B  
C  
TF  
E  
F  
G  
H  
I  
J  
K  
L  
M  
N  
O  
P

# PRECAUTIONS

< SERVICE INFORMATION >

## PRECAUTIONS

### Precaution for Supplemental Restraint System (SRS) "AIR BAG" and "SEAT BELT PRE-TENSIONER"

INFOID:000000003464654

The Supplemental Restraint System such as "AIR BAG" and "SEAT BELT PRE-TENSIONER", used along with a front seat belt, helps to reduce the risk or severity of injury to the driver and front passenger for certain types of collision. This system includes seat belt switch inputs and dual stage front air bag modules. The SRS system uses the seat belt switches to determine the front air bag deployment, and may only deploy one front air bag, depending on the severity of a collision and whether the front occupants are belted or unbelted. Information necessary to service the system safely is included in the "SUPPLEMENTAL RESTRAINT SYSTEM" and "SEAT BELTS" of this Service Manual.

#### **WARNING:**

- To avoid rendering the SRS inoperative, which could increase the risk of personal injury or death in the event of a collision which would result in air bag inflation, all maintenance must be performed by an authorized NISSAN/INFINITI dealer.
- Improper maintenance, including incorrect removal and installation of the SRS, can lead to personal injury caused by unintentional activation of the system. For removal of Spiral Cable and Air Bag Module, see the "SUPPLEMENTAL RESTRAINT SYSTEM".
- Do not use electrical test equipment on any circuit related to the SRS unless instructed to in this Service Manual. SRS wiring harnesses can be identified by yellow and/or orange harnesses or harness connectors.

### PRECAUTIONS WHEN USING POWER TOOLS (AIR OR ELECTRIC) AND HAMMERS

#### **WARNING:**

- When working near the Air Bag Diagnosis Sensor Unit or other Air Bag System sensors with the ignition ON or engine running, DO NOT use air or electric power tools or strike near the sensor(s) with a hammer. Heavy vibration could activate the sensor(s) and deploy the air bag(s), possibly causing serious injury.
- When using air or electric power tools or hammers, always switch the ignition OFF, disconnect the battery, and wait at least 3 minutes before performing any service.

### Precaution

INFOID:000000002955673

- Before connecting or disconnecting the AWD control unit harness connector, turn ignition switch "OFF" and disconnect battery ground cable. Because battery voltage is applied to AWD control unit even if ignition switch is turned "OFF".

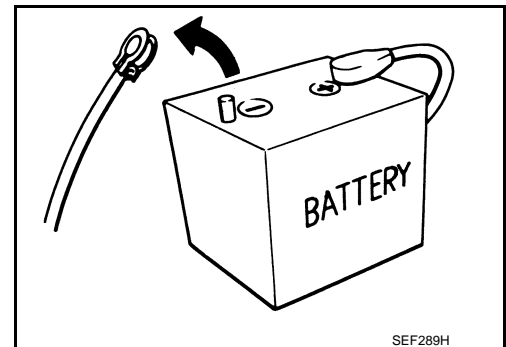

- When connecting or disconnecting pin connectors into or from AWD control unit, take care not to damage pin terminals (bend or break).  
When connecting pin connectors, make sure that there are no bends or breaks on AWD control unit pin terminal.

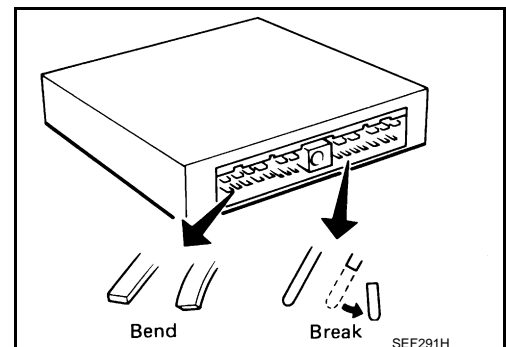

# PRECAUTIONS

## < SERVICE INFORMATION >

- Before replacing AWD control unit, perform AWD control unit input/output signal inspection and make sure whether AWD control unit functions properly or not. Refer to [TF-21, "AWD Control Unit Input/Output Signal Reference Value"](#).

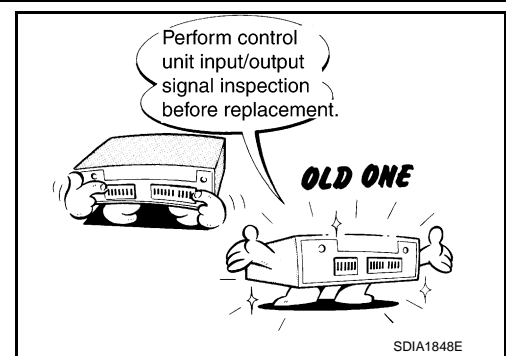

## Service Notice or Precaution

INFOID:00000002955674

- Do not reuse transfer fluid, once it has been drained.
- Check the fluid level or replace the fluid only with the vehicle parked on level ground.
- During removal or installation, keep inside of transfer clear of dust or dirt.
- Replace all tires at the same time. Always use tires of the proper size and the same brand and pattern. Fitting improper size and unusual wear tires applies excessive force to vehicle mechanism and can cause longitudinal vibration.
- Disassembly should be done in a clean work area, it is preferable to work in dustproof area.
- Before proceeding with disassembly, thoroughly clean the transfer. It is important to prevent the internal parts from becoming contaminated by dirt or other foreign matter.
- All parts should be carefully cleaned with a general purpose, non-flammable solvent before inspection or reassembly.
- Check for the correct installation status prior to removal or disassembly. If matching marks are required, be certain they do not interfere with the function of the parts when applied.
- Check appearance of the disassembled parts for damage, deformation, and unusual wear. Replace them with a new ones if necessary.
- Gaskets, seals and O-rings should be replaced any time when the transfer is disassembled.
- In principle, tighten bolts or nuts gradually in several steps working diagonally from inside to outside. If tightening sequence is specified, use it.
- Observe the specified torque when assembling.
- Clean and flush the parts sufficiently and blow-dry them.
- Be careful not to damage sliding surfaces and mating surfaces.
- Clean inner parts with lint-free cloth or towels. Do not use cotton work gloves and rags to prevent adhering fibers.

# PREPARATION

< SERVICE INFORMATION >

## PREPARATION

### Special Service Tool

INFOID:000000002955675

The actual shapes of Kent-Moore tools may differ from those of special service tools illustrated here.

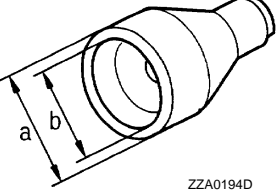
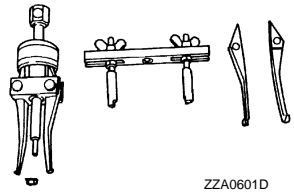
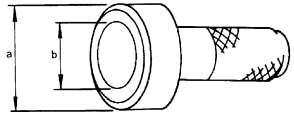
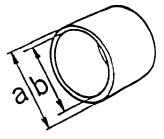
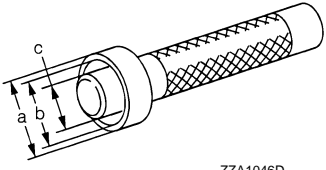
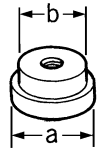
Tool number (Kent-Moore No.) Tool name	Description
ST27862000 ( — ) Drift a: 62.5 mm (2.461 in) dia. b: 42 mm (1.65 in) dia.  ZZA0194D	<ul style="list-style-type: none"> <li>Installing front oil seal</li> </ul>
KV381054S0 (J-34286) Puller  ZZA0601D	<ul style="list-style-type: none"> <li>Removing rear oil seal</li> </ul>
ST30720000 (J-25405) Drift a: 77 mm (3.03 in) dia. b: 55.5 mm (2.185 in) dia.  ZZA0811D	<ul style="list-style-type: none"> <li>Installing rear oil seal</li> <li>Installing mainshaft oil seal</li> </ul>
KV40104830 ( — ) Drift a: 70 mm (2.76 in) dia. b: 63.5 mm (2.500 in) dia.  ZZA1003D	<ul style="list-style-type: none"> <li>Installing rear oil seal</li> </ul>
KV38100300 (J-25523) Drift a: 54 mm (2.13 in) dia. b: 46 mm (1.81 in) dia. c: 32 mm (1.26 in) dia.  ZZA1046D	<ul style="list-style-type: none"> <li>Removing mainshaft bearing</li> </ul>
ST33052000 ( — ) Drift a: 28 mm (1.10 in) dia. b: 22 mm (0.87 in) dia.  ZZA1000D	<ul style="list-style-type: none"> <li>Removing mainshaft assembly</li> </ul>

# PREPARATION

## < SERVICE INFORMATION >

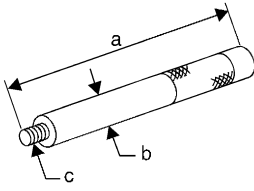
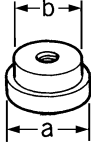
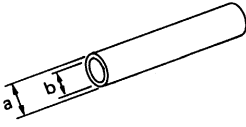
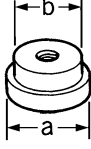
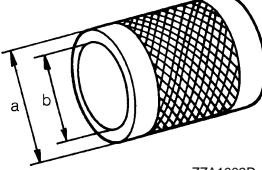
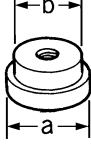
Tool number (Kent-Moore No.) Tool name	Description	
ST30611000 (J-25742-1) Drift bar a: 350 mm (1.10 in) b: 25 mm (1.10 in) dia. c: M12 × 1.5P	 • Removing rear bearing	A B C
ST35321000 ( — ) Drift a: 49 mm (1.93 in) dia. b: 41 mm (1.61 in) dia.	 • Removing rear bearing • Installing mainshaft assembly	TF E F
ST31214000 (J-25269-B) Drift a: 34 mm (1.34 in) dia. b: 25.5 mm (1.004 in) dia.	 • Removing front drive shaft front bearing • Removing front drive shaft rear bearing	G H
KV38104010 ( — ) Drift a: 67 mm (2.64 in) dia. b: 49 mm (1.93 in) dia.	 • Installing front drive shaft rear bearing • Installing rear bearing	I J K
ST33200000 (J-26082) Drift a: 60 mm (2.36 in) dia. b: 44.5 mm (1.752 in) dia.	 • Installing front drive shaft front bearing	L M
ST30621000 (J-25742-5) Drift a: 80 mm (3.15 in) dia. b: 59 mm (2.32 in) dia.	 • Installing mainshaft bearing	N O P

Commercial Service Tool

INFOID:000000002955676

# PREPARATION

## < SERVICE INFORMATION >

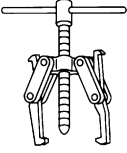
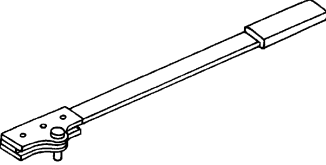
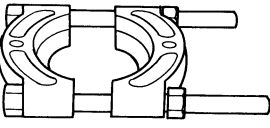
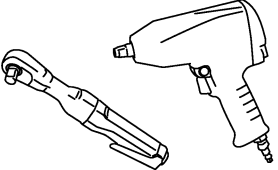
Tool name	Description
<p data-bbox="164 199 224 226">Puller</p>  <p data-bbox="829 415 873 436">NT077</p>	<ul data-bbox="1010 199 1323 226" style="list-style-type: none"><li>• Removing companion flange</li></ul>
<p data-bbox="164 451 316 478">Flange wrench</p>  <p data-bbox="829 667 873 688">NT771</p>	<ul data-bbox="1010 451 1404 478" style="list-style-type: none"><li>• Removing and installing self-lock nut</li></ul>
<p data-bbox="164 703 224 730">Puller</p>  <p data-bbox="829 919 901 940">ZZB0823D</p>	<ul data-bbox="1010 703 1437 814" style="list-style-type: none"><li>• Removing front drive shaft front bearing</li><li>• Removing front drive shaft rear bearing</li><li>• Removing companion flange (VK45DE models)</li></ul>
<p data-bbox="164 955 272 982">Power tool</p>  <p data-bbox="829 1171 901 1192">PBIC0190E</p>	<ul data-bbox="1010 955 1291 982" style="list-style-type: none"><li>• Loosening bolts and nuts</li></ul>



# NOISE, VIBRATION AND HARSHNESS (NVH) TROUBLESHOOTING

< SERVICE INFORMATION >

## NOISE, VIBRATION AND HARSHNESS (NVH) TROUBLESHOOTING

### NVH Troubleshooting Chart

INFOID:000000002955677

Use the chart below to help you find the cause of the symptom. The numbers indicate the order of the inspection. If necessary, repair or replace these parts.

Reference page		IF-10			IF-41	IF-41	IF-41	IF-41	IF-41
SUSPECTED PARTS (Possible cause)		TRANSFER FLUID (Level low)	TRANSFER FLUID (Wrong)	TRANSFER FLUID (Level too high)	LIQUID GASKET (Damaged)	OIL SEAL (Worn or damaged)	GEAR (Worn or damaged)	BEARING (Worn or damaged)	TRANSFER CASE (Damaged)
Symptom	Noise	1	2				3	3	3
	Transfer fluid leakage		4	1	2	2			3

A  
B  
C  
TF  
E  
F  
G  
H  
I  
J  
K  
L  
M  
N  
O  
P

# TRANSFER FLUID

< SERVICE INFORMATION >

## TRANSFER FLUID

### Replacement

INFOID:000000002955678

#### DRAINING

1. Run the vehicle to warm up the transfer unit sufficiently.
2. Stop the engine, and remove the drain plug to drain the transfer fluid.

**CAUTION:**

**When draining fluid, protect exhaust tube flange with cover.**

3. Apply sealant to drain plug. Install drain plug on transfer and tighten to the specified torque. Refer to [TF-41, "Disassembly and Assembly"](#).

• Use Genuine Silicone RTV or equivalent. Refer to [GI-44, "Recommended Chemical Product and Sealant"](#).

**CAUTION:**

**Remove old sealant adhering to mounting surfaces. Also remove any moisture, oil, or foreign material adhering to application and mounting surfaces.**

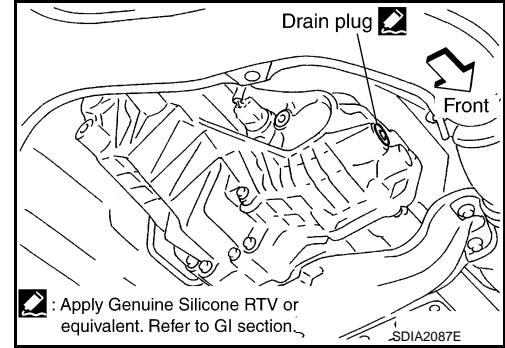

#### FILLING

1. Remove filler plug and add transfer fluid until fluid level reaches the specified limit near filler plug mounting hole.

**Fluid capacity**

: Approx. 1.25 l (2-5/8 US pt, 2-1/4 Imp pt)

**CAUTION:**

**Carefully fill the fluid. (Fill up for approx. 3 minutes.)**

2. Leave the vehicle for 3 minutes, and check the fluid level again.
3. Set a new gasket onto filler plug and install it on transfer and tighten to the specified torque. Refer to [TF-41, "Disassembly and Assembly"](#).

**CAUTION:**

**Do not reuse gasket.**

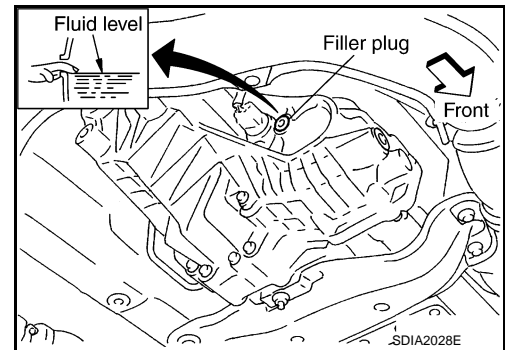

### Inspection

INFOID:000000002955679

#### FLUID LEAKAGE AND FLUID LEVEL

1. Check if fluid is leaking from transfer or around it.
2. Check fluid level from filler plug mounting hole as shown in the figure.

**CAUTION:**

**Never start engine while checking fluid level.**

3. Before installing filler plug, set a new gasket. Install filler plug on transfer and tighten to the specified torque. Refer to [TF-41, "Disassembly and Assembly"](#).

**CAUTION:**

**Do not reuse gasket.**

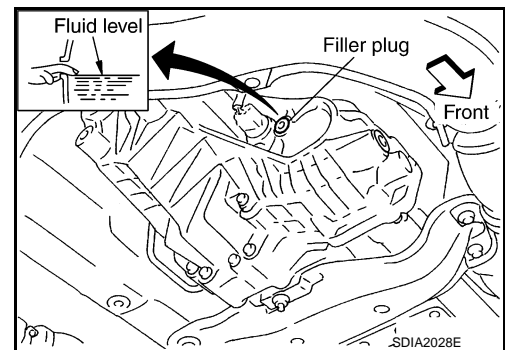

# AWD SYSTEM

< SERVICE INFORMATION >

## AWD SYSTEM

### Power Transfer Diagram

INFOID:000000002955680

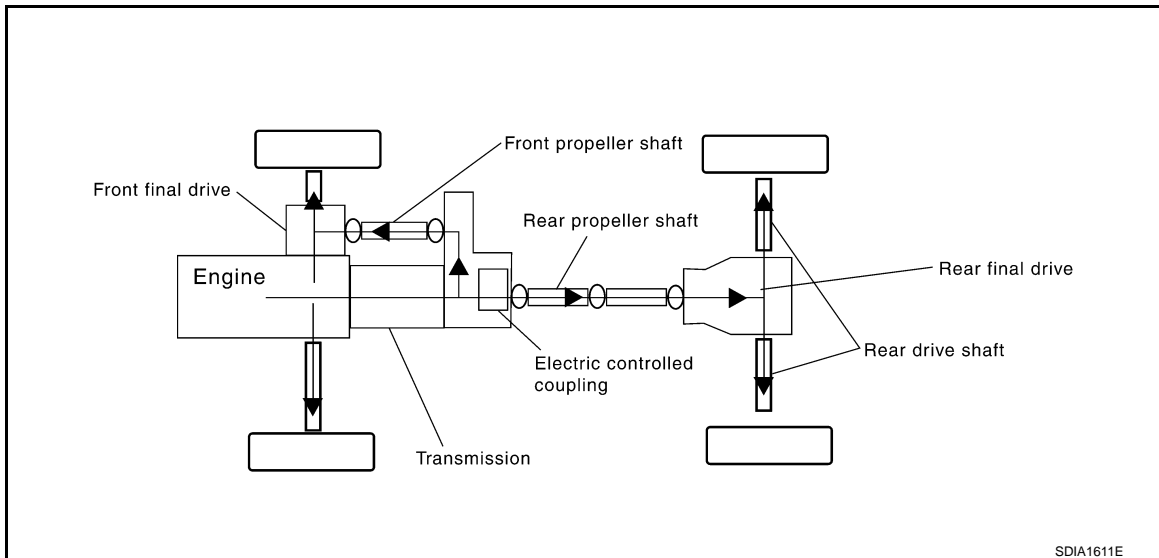

### System Description

INFOID:000000002955681

#### DESCRIPTION

- Electronic control allows optimal distribution of torque to front/rear wheels to match road conditions.
- Makes possible stable driving, with no wheel spin, on snowy roads or other slippery surfaces.
- On roads which do not require AWD, it contributes to improved fuel economy by driving in conditions close to rear-wheel drive.
- Sensor inputs determine the vehicle's turning condition, and in response tight cornering/braking are controlled by distributing optimum torque to front wheels.

#### NOTE:

- When driving, if there is a large difference between front and rear wheel speed which continues for a long time, fluid temperature of drive system parts becomes too high and AWD warning lamp flashes rapidly. (When AWD warning lamp flashes, vehicle changes to rear-wheel drive conditions.) Also, optional distribution of torque sometimes becomes rigid before lamp flashes rapidly, but it is not malfunction.
- If AWD warning lamp is flashing rapidly, stop vehicle and allow it to idle for some time. Flashing will stop and AWD system will be restored.
- When driving, AWD warning lamp may flash slowly if there is a significant difference in diameter of the tires. At this time, vehicle performance is not fully available and cautious driving is required. (Continues until engine is turned OFF.)
- If the warning lamp flashes slowly during driving but remains OFF after engine is restarted, the system is normal. If it again flashes slowly after driving for some time, vehicle must be inspected.
- When the difference of revolution speed between the front and rear wheel the shift occasionally changes to direct 4-wheel driving conditions automatically. This is not malfunction.

#### ELECTRIC CONTROLLED COUPLING

##### Operation Principle

# AWD SYSTEM

## < SERVICE INFORMATION >

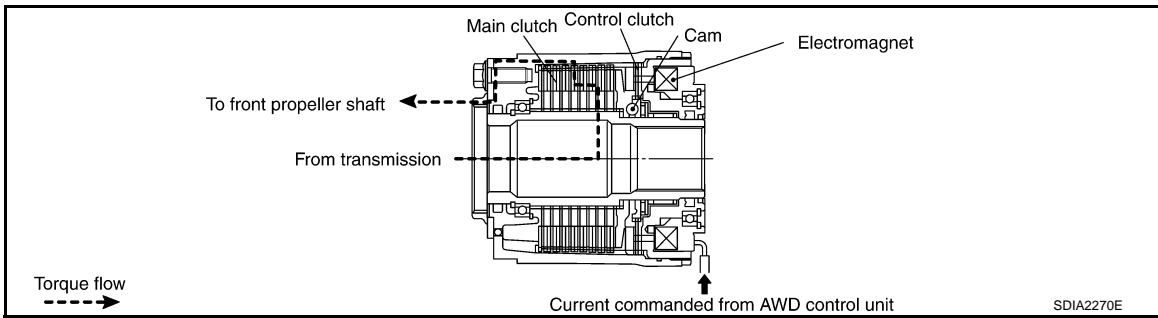

1. AWD control unit supplies command current to electric controlled coupling (AWD solenoid).
2. Control clutch is engaged by electromagnet and torque is detected in control clutch.
3. The cam operates in response to control clutch torque and applies pressure to main clutch.
4. Main clutch transmits torque to front wheels according to pressing power.
  - Transmission torque to front wheels is determined according to command current.

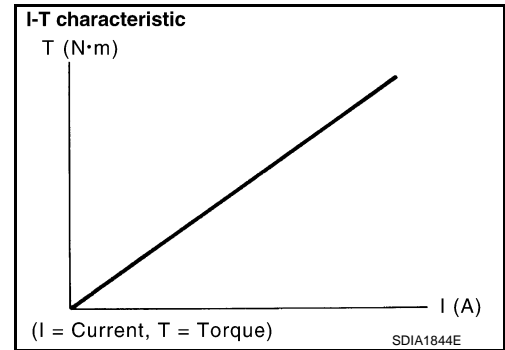

### AWD CONTROL UNIT

- Controls distribution of drive power between rear-wheel drive (0:100) and AWD (50:50) conditions according to signals from sensors.
- Self-diagnosis can be done with CONSULT-III.

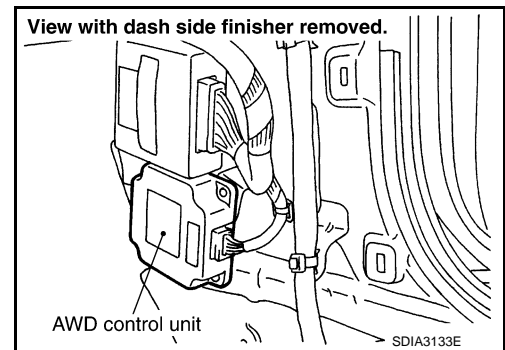

### AWD WARNING LAMP

Turns ON when there is a malfunction in AWD system. It indicates that fail-safe mode is engaged and vehicle change to rear-wheel drive or shifting driving force-AWD (Front-wheels still have some driving torque). Also turns ON when ignition switch is turned ON, for purpose of lamp check. Turns OFF approximately for 1 seconds after the engine starts if system is normal.

#### AWD Warning Lamp Indication

Condition	AWD warning lamp
Lamp check	Turns ON when ignition switch is turned ON. Turns OFF approx. 1 second after engine start.
AWD system malfunction	ON
Protection function is activated due to heavy load to electric controlled coupling. (AWD system is not malfunctioning and AWD system changes to 2WD mode.)	Rapid flashing: 2 times/second (Flashing in approx. 1 minute and then turning OFF)
Large difference in diameter of front/rear tires	Slow flashing: 1 time/2 seconds (Continuing to flash until turning ignition switch OFF)
Other than above (system normal)	OFF

# AWD SYSTEM

< SERVICE INFORMATION >

## Schematic

INFOID:000000002955682

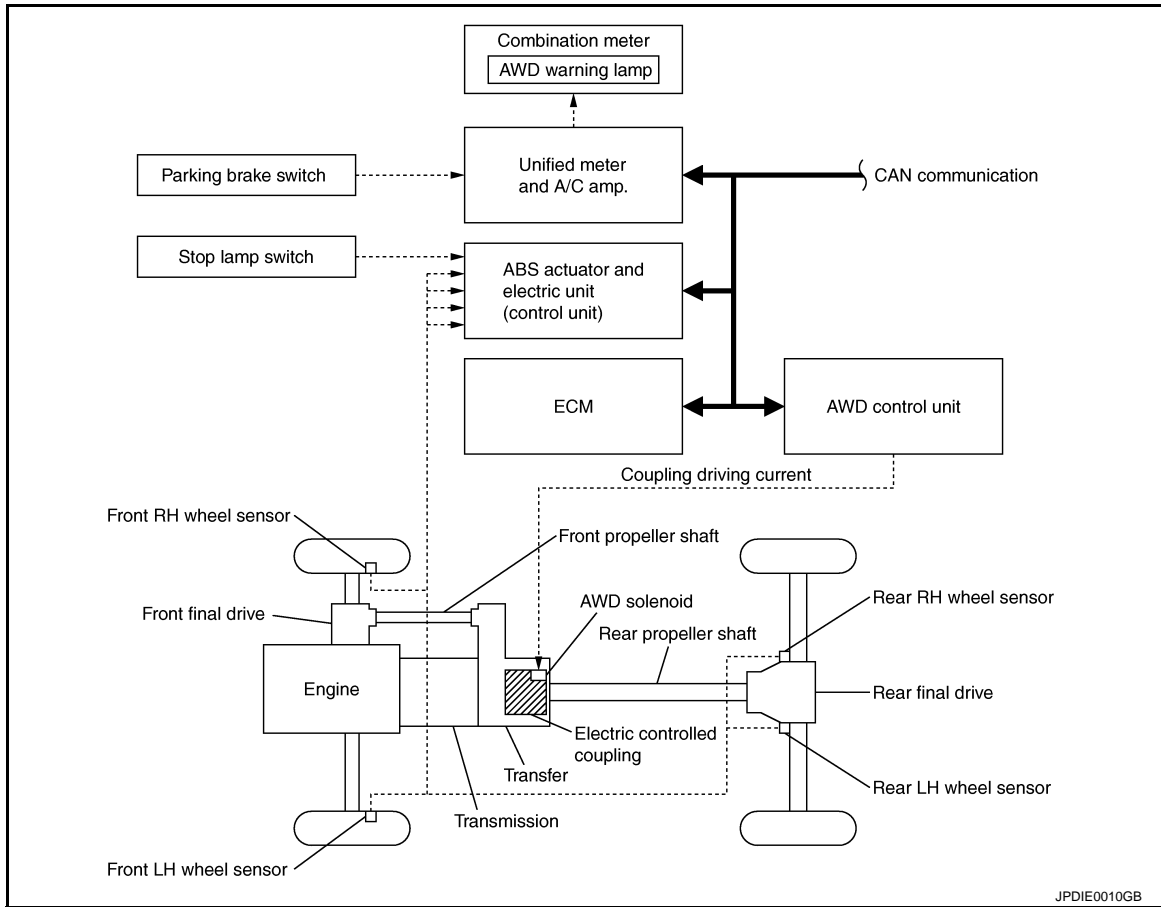

## COMPONENTS FUNCTION DESCRIPTION

Component parts	Function
AWD control unit	<ul style="list-style-type: none"> <li>Controls driving force distribution by signals from each sensor and switch from rear wheel driving mode (0:100) to AWD mode (50:50).</li> <li>2WD mode is available by fail-safe function if malfunction is detected in AWD system.</li> </ul>
Wheel sensors	Detects wheel speed.
AWD solenoid	Controls electric controlled coupling by command current from AWD control unit.
Electric controlled coupling	Transmits driving force to front final drive.
AWD warning lamp	<ul style="list-style-type: none"> <li>Illuminates if malfunction is detected in electrical system of AWD system.</li> <li>There is 1 blink in 2 seconds if rotation difference of front wheels and rear wheels is large.</li> <li>There are 2 blinks in 1 second if load is still applied to driving parts.</li> </ul>
ABS actuator and electric unit (control unit)	Transmits the following signals via CAN communication to AWD control unit. <ul style="list-style-type: none"> <li>Vehicle speed signal</li> <li>Stop lamp switch signal (brake signal)</li> </ul>
ECM	Transmits the following signals via CAN communication to AWD control unit. <ul style="list-style-type: none"> <li>Accelerator pedal position signal</li> <li>Engine speed signal</li> </ul>
Unified meter and A/C amp.	Transmits conditions of parking brake switch via CAN communication to AWD control unit.

## CAN Communication

INFOID:0000000002955683

## SYSTEM DESCRIPTION

CAN (Controller Area Network) is a serial communication line for real time application. It is an on-vehicle multiplex communication line with high data communication speed and excellent error detection ability. Many electronic control units are equipped onto a vehicle, and each control unit shares information and links with other

## AWD SYSTEM

### < SERVICE INFORMATION >

---

control units during operation (not independent). In CAN communication, control units are connected with 2 communication lines (CAN H line, CAN L line) allowing a high rate of information transmission with less wiring. Each control unit transmits/receives data but selectively reads required data only.

For details, refer to [LAN-29, "CAN System Specification Chart"](#).

# TROUBLE DIAGNOSIS

< SERVICE INFORMATION >

## TROUBLE DIAGNOSIS

### Fail-Safe Function

INFOID:000000002955684

- If any malfunction occurs in AWD electrical system, and control unit detects the malfunction, AWD warning lamp on combination meter turns ON to indicate system malfunction.
- When AWD warning lamp is ON, vehicle changes to rear-wheel drive or shifting driving force-AWD (Front-wheels still have some driving torque).

### How to Perform Trouble Diagnosis

INFOID:000000002955685

#### BASIC CONCEPT

- To perform trouble diagnosis, it is the most important to have understanding about vehicle systems (control and mechanism) thoroughly.
- It is also important to clarify customer complaints before inspection.

First of all, reproduce symptoms, and understand them fully. Ask customer about his/her complaints carefully. In some cases, it will be necessary to check symptoms by driving vehicle with customer.

#### CAUTION:

**Customers are not professional. It is dangerous to make an easy guess like “maybe the customer means that...,” or “maybe the customer mentions this symptom”.**

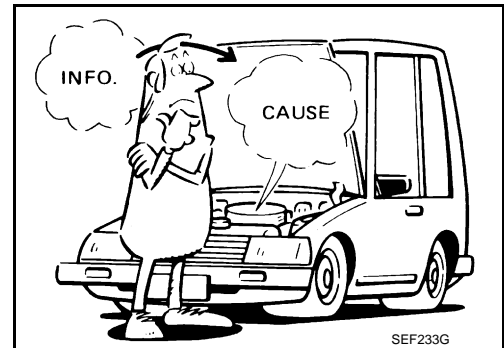

- It is essential to check symptoms right from the beginning in order to repair malfunctions completely. For intermittent malfunctions, reproduce symptoms based on interview with customer and past examples. Do not perform inspection on ad hoc basis. Most intermittent malfunctions are caused by poor contacts. In this case, it will be effective to shake suspected harness or connector by hand. When repairing without any symptom diagnosis, you cannot judge if malfunctions have actually been eliminated.
- After completing diagnosis, always erase diagnostic memory. Refer to [TF-22, "CONSULT-III Function \(ALL MODE AWD/4WD\)"](#).
- For intermittent malfunctions, move harness or harness connector by hand. Then check for poor contact or reproduced open circuit.

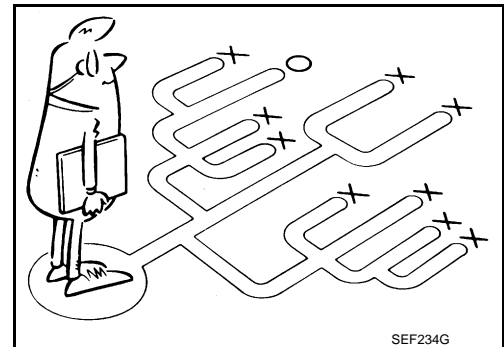

A  
B  
C  
TF  
E  
F  
G  
H  
I  
J  
K  
L  
M  
N  
O  
P

# TROUBLE DIAGNOSIS

< SERVICE INFORMATION >

## Location of Electrical Parts

INFOID:00000002955686

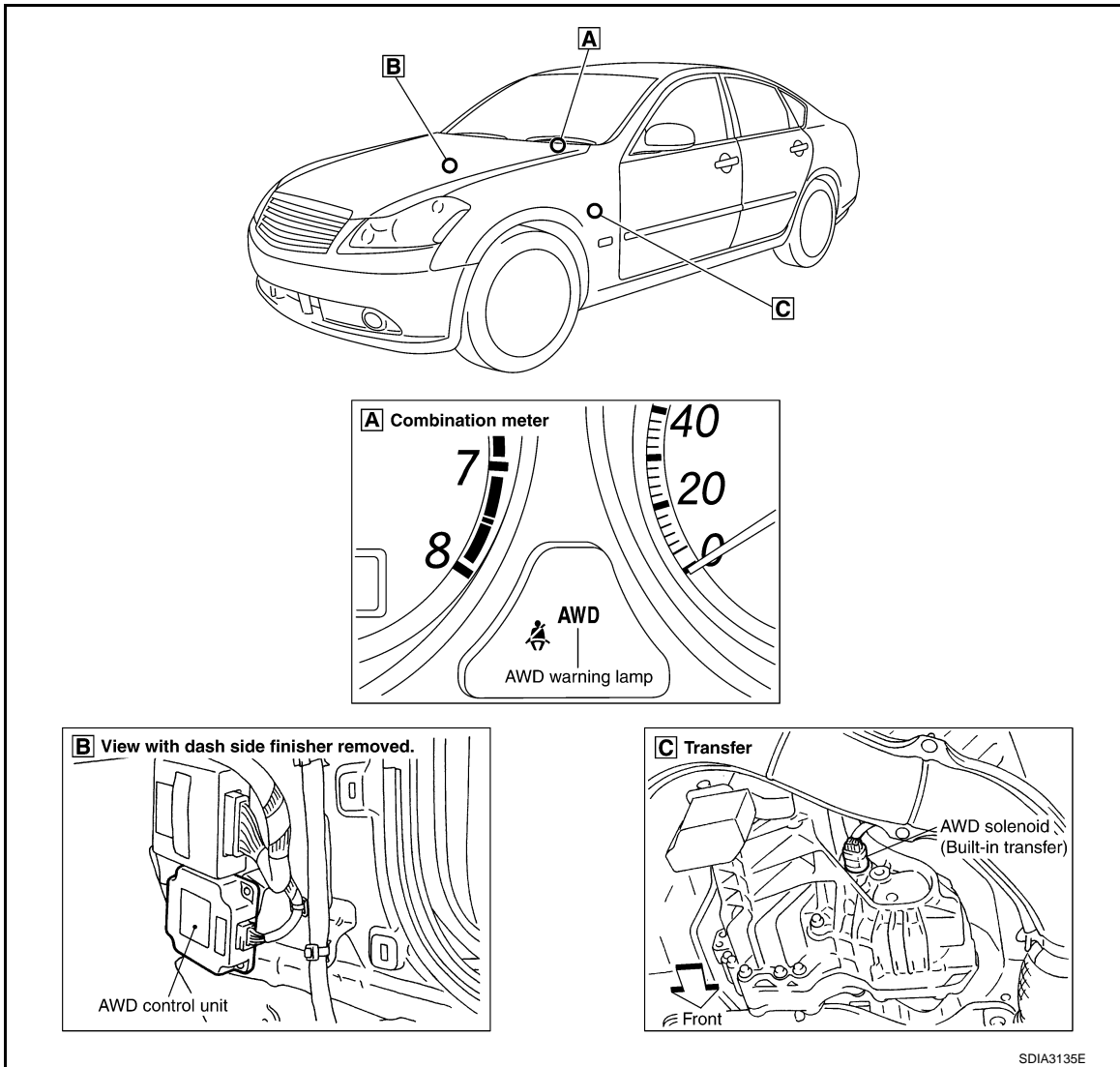



# TROUBLE DIAGNOSIS

< SERVICE INFORMATION >

## Circuit Diagram

INFOID:000000002955687

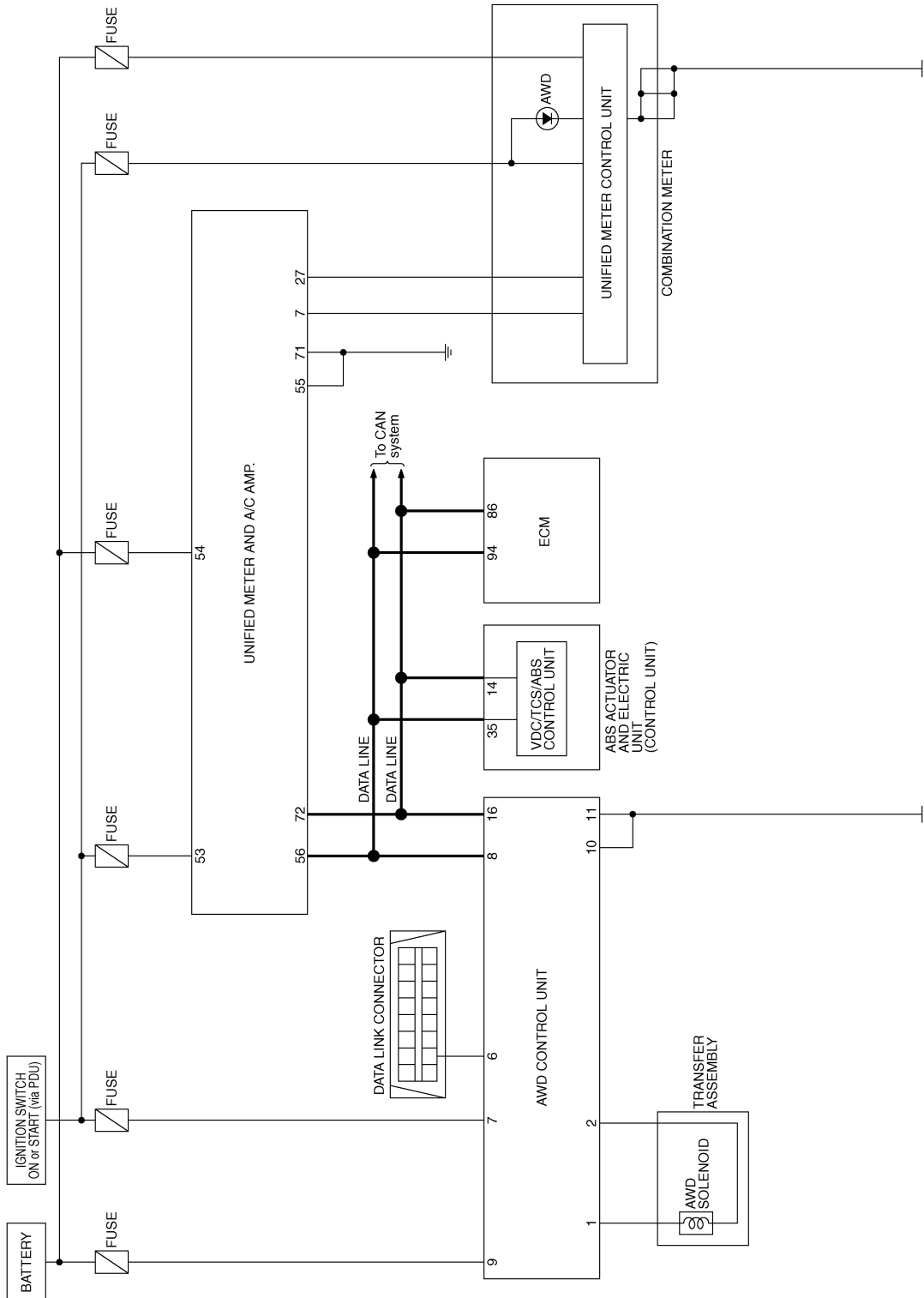

A  
B  
C  
TF  
E  
F  
G  
H  
I  
J  
K  
L  
M  
N  
O  
P

TDWT0017E

# TROUBLE DIAGNOSIS

< SERVICE INFORMATION >

Wiring Diagram - AWD -

INFOID:00000002955688

TF-AWD-01

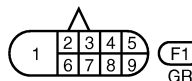
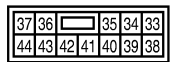
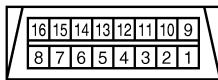
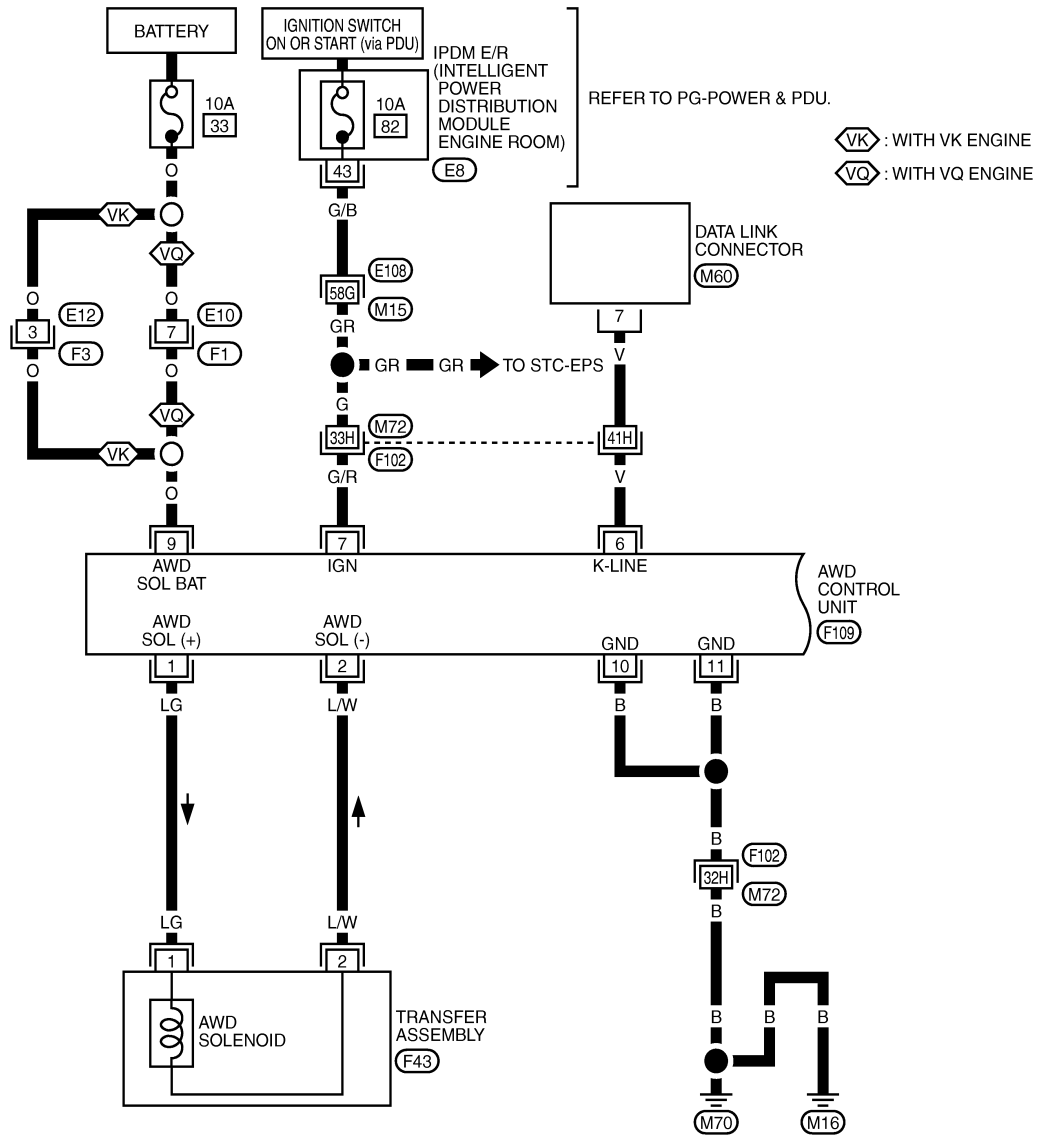

REFER TO THE FOLLOWING.  
 (E108), (F102) - SUPER MULTIPLE JUNCTION (SMJ)

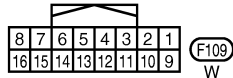
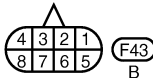
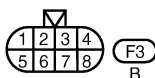

TDWT0042E

# TROUBLE DIAGNOSIS

< SERVICE INFORMATION >

TF-AWD-02

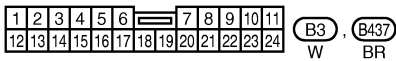
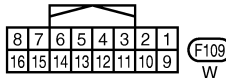
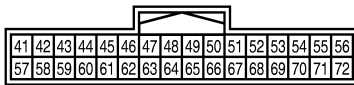
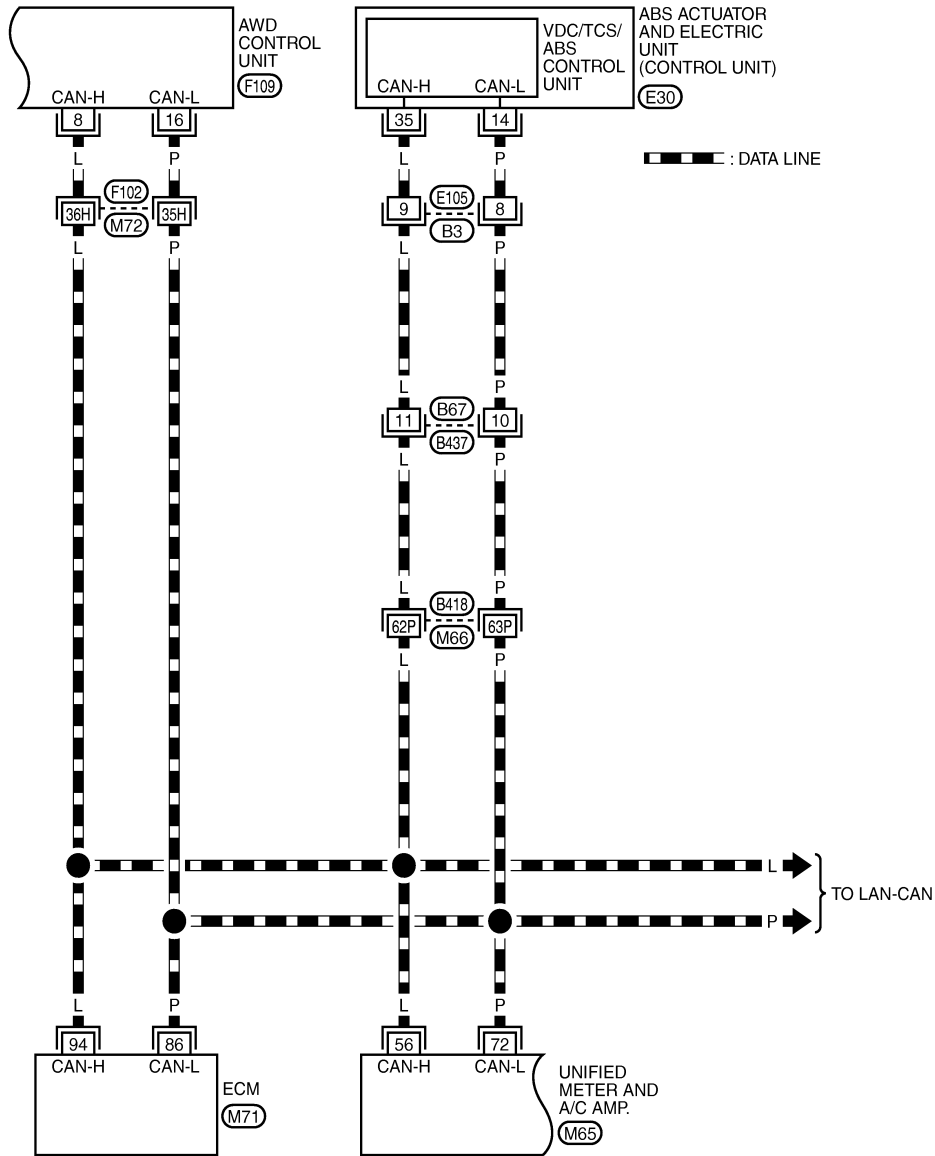

REFER TO THE FOLLOWING.  
 (F102), (B418) - SUPER MULTIPLE JUNCTION (SMJ)  
 (M71), (E30) - ELECTRICAL UNITS

TDWT0043E

A  
B  
C  
TF  
E  
F  
G  
H  
I  
J  
K  
L  
M  
N  
O  
P

# TROUBLE DIAGNOSIS

< SERVICE INFORMATION >

## TF-AWD-03

VK : WITH VK ENGINE  
VQ : WITH VQ ENGINE

REFER TO PG-POWER & PDU.

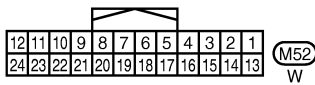
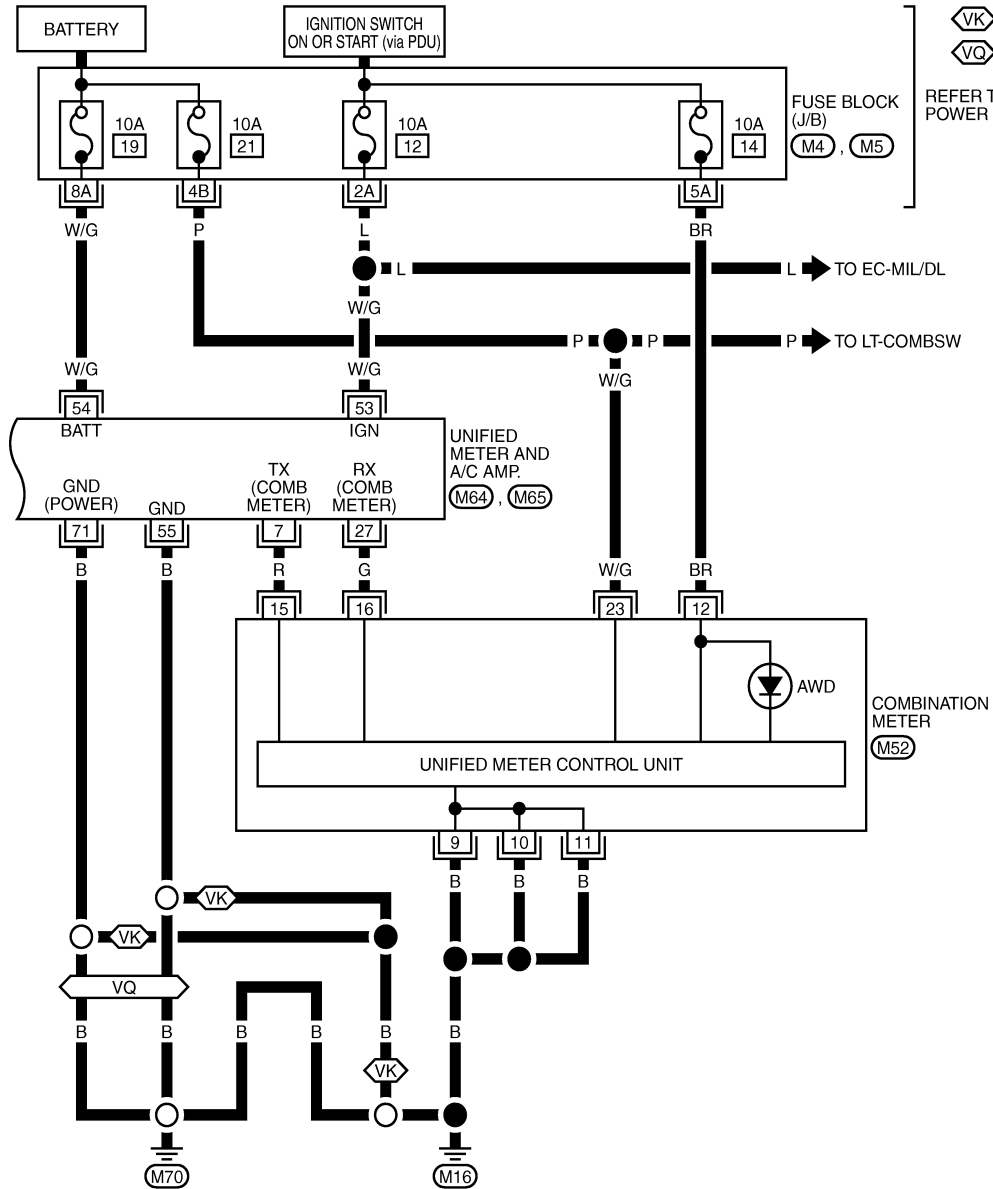

REFER TO THE FOLLOWING.

M4 , M5 - FUSE BLOCK - JUNCTION BOX (J/B)

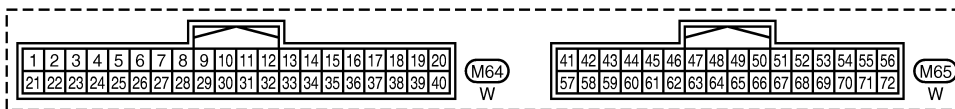

TDWT0044E

# TROUBLE DIAGNOSIS

< SERVICE INFORMATION >

## Trouble Diagnosis Chart by Symptom

INFOID:000000002955689

If AWD warning lamp turns ON, perform self-diagnosis. Refer to [TF-22, "CONSULT-III Function \(ALL MODE AWD/4WD\)"](#).

Symptom	Condition	Check item	Reference page
AWD warning lamp does not turn ON when the ignition switch is turned to ON. (AWD warning lamp check)	Ignition switch: ON	CAN communication line	<a href="#">TF-31</a>
		Unified meter and A/C amp.	
		Unified meter control unit	
AWD warning lamp does not turn OFF several seconds after engine started.	Engine running	CAN communication line	<a href="#">TF-31</a>
		Power supply and ground for AWD control unit	
		Unified meter and A/C amp.	
		Unified meter control unit	
		AWD solenoid	
		AWD actuator relay (integrated in AWD control unit)	
		Wheel sensor	
Heavy tight-corner braking symptom occurs when the vehicle is driven and the steering wheel is turned fully to either side after the engine is started. (See NOTE.)	<ul style="list-style-type: none"> <li>While driving</li> <li>Steering wheel is turned fully to either sides</li> </ul>	CAN communication line	<a href="#">TF-33</a>
		Accelerator pedal position signal	
		AWD solenoid	
		Mechanical malfunction of electric controlled coupling (clutch sticking etc.)	
Vehicle does not enter AWD mode even though AWD warning lamp turned to OFF.	While driving	CAN communication line	<a href="#">TF-34</a>
		AWD solenoid	
		Mechanical malfunction of electric controlled coupling (Mechanical engagement of clutch is not possible.)	
While driving, AWD warning lamp flashes rapidly. (When flashing in approx. 1 minute and then turning OFF.) Rapid flashing: 2 times/second	While driving	Protection function is activated due to heavy load to electric controlled coupling. (AWD system is not malfunctioning. Also, optional distribution of torque sometimes becomes rigid before lamp flashes rapidly, but it is not malfunction.)	<a href="#">TF-34</a>
While driving, AWD warning lamp flashes slowly. (When continuing to flash until turning ignition switch OFF) Slow flashing: 1 time/2 seconds	<ul style="list-style-type: none"> <li>While driving</li> <li>Vehicle speed: 20 km/h (12 MPH) or more</li> </ul>	Tire size is different between front and rear of vehicle.	<a href="#">TF-35</a>

### NOTE:

Light tight-corner braking symptom may occur depending on driving conditions. This is not malfunction.

## AWD Control Unit Input/Output Signal Reference Value

INFOID:000000002955690

### AWD CONTROL UNIT INSPECTION TABLE

Specifications with CONSULT-III

Monitor item [Unit]	Content	Condition	Display value
FR RH SENSOR [km/h] or [mph]	Wheel speed (Front wheel right)	Vehicle stopped	0.00 km/h (0.00 mph)
		Vehicle running <b>CAUTION:</b> Check air pressure of tire under standard condition.	Approximately equal to the indication on speedometer (Inside of ±10%)

# TROUBLE DIAGNOSIS

## < SERVICE INFORMATION >

Monitor item [Unit]	Content	Condition	Display value
FR LH SENSOR [km/h] or [mph]	Wheel speed (Front wheel left)	Vehicle stopped	0.00 km/h (0.00 mph)
		Vehicle running <b>CAUTION:</b> Check air pressure of tire under standard condition.	Approximately equal to the indication on speedometer (Inside of ±10%)
RR RH SENSOR [km/h] or [mph]	Wheel speed (Rear wheel right)	Vehicle stopped	0.00 km/h (0.00 mph)
		Vehicle running <b>CAUTION:</b> Check air pressure of tire under standard condition.	Approximately equal to the indication on speedometer (Inside of ±10%)
RR LH SENSOR [km/h] or [mph]	Wheel speed (Rear wheel left)	Vehicle stopped	0.00 km/h (0.00 mph)
		Vehicle running <b>CAUTION:</b> Check air pressure of tire under standard condition.	Approximately equal to the indication on speedometer (Inside of ±10%)
BATTERY VOLT [V]	Power supply voltage for AWD control unit	Ignition switch: ON	Battery voltage
THRTL POS SEN [%]	Throttle opening condition	When depressing accelerator pedal (Value rises gradually in response to throttle position.)	0 - 100%
ETS SOLENOID [A]	Monitored value of current at AWD solenoid	Engine running • At idle speed	Approx. 0.000A
		Engine running • When depressing accelerator pedal	Approx. 0.000 - 0.500A*1
STOP LAMP SW [ON/OFF]	Condition of brake pedal operation	Brake pedal: Depressed	On
		Brake pedal: Released	Off
ENG SPEED SIG [RUN/STOP]	Condition of engine running	Engine stopped (Engine speed: Less than 400 rpm)	STOP
		Engine running (Engine speed: 400 rpm or more)	RUN
ETS ACTUATOR [ON/OFF]	Operating condition of AWD actuator relay (integrated in AWD control unit)	Engine stopped (Ignition switch: ON)	Off
		Engine running	On
4WD WARN LAMP [ON/OFF]	AWD warning lamp condition	AWD warning lamp: ON	On
		AWD warning lamp: OFF	Off
4WD MODE SW*2 [AUTO]	Input condition from mode switch	Always	AUTO
4WD MODE MON [AUTO]	Control status of AWD	Engine running	AUTO
DIS-TIRE MONI [mm]	Improper size tire installed condition	Vehicle running with normal size tire installed	0-4 mm
		Vehicle running with improper size tire installed (Front/rear tire size difference, wear condition)	4-8 mm, 8- mm
P BRAKE SW [ON/OFF]	Condition of parking brake	Parking brake operated	On
		Parking brake not operated	Off

\*1: The values are changed by throttle opening and engine speed.

\*2: Mode switch is not equipped, but displayed.

## CONSULT-III Function (ALL MODE AWD/4WD)

INFOID:000000002955691

### FUNCTION

CONSULT-III can display each diagnostic item using the diagnostic test modes shown following.

# TROUBLE DIAGNOSIS

## < SERVICE INFORMATION >

Diagnostic test mode	Function
Self-diagnostic results	<ul style="list-style-type: none"> <li>Self-diagnostic results can be read and erased quickly.</li> </ul>
Data monitor	<ul style="list-style-type: none"> <li>Input/Output data in the AWD control unit can be read.</li> </ul>
Active test	<ul style="list-style-type: none"> <li>Diagnostic Test Mode in which CONSULT-III drives some actuators apart from the AWD control unit and also shifts some parameters in a specified range.</li> </ul>
ECU part number	<ul style="list-style-type: none"> <li>AWD control unit part number can be read.</li> </ul>

### SELF-DIAG RESULT MODE

Drive at 30 km/h (19 MPH) or more for approximately 1 minute before performing the self-diagnosis.

Display Item List

Items (CONSULT-III screen terms)	Diagnostic item is detected when...	Check item
CONTROLLER FAILURE [C1201]	Malfunction has occurred inside AWD control unit.	<a href="#">TF-26, "AWD Control Unit"</a>
ABS SYSTEM [C1203]	Malfunction related to wheel sensor has been detected by ABS actuator and electric unit (control unit).	<a href="#">TF-26, "ABS System"</a>
4WD SOLENOID [C1204]	Malfunction related to AWD solenoid has been detected.	<a href="#">TF-27, "AWD Solenoid"</a>
4WD ACTUATOR RLY [C1205]	Malfunction has been detected from AWD actuator relay integrated with AWD control unit, or malfunction related to AWD solenoid has been detected.	<a href="#">TF-28, "AWD Actuator Relay"</a> or <a href="#">TF-27, "AWD Solenoid"</a>
ENGINE SIGNAL 1 [C1210]	Malfunction has been detected from ECM.	<a href="#">TF-29, "Engine Control Signal"</a>
CAN COMM CIRCUIT [U1000]	When AWD control unit is not transmitting or receiving CAN communication signal for 2 seconds or more.	<a href="#">TF-30, "CAN Communication Line"</a>
NO DTC IS DETECTED. FURTHER TESTING MAY BE REQUIRED.	No NG item has been detected.	—

#### CAUTION:

- If "CAN COMM CIRCUIT [U1000]" is displayed with other DTCs, first perform the trouble diagnosis for CAN communication line.
- Make sure that ABS warning lamp turns OFF by driving for a minute at vehicle speed of 30 km/h (19 MPH) or more after turning ignition switch "OFF" if AWD warning lamp turns ON with system malfunction of "ABS SYSTEM [C1203]". AWD warning lamp may not turn OFF if it is normal unless ignition switch turns OFF at once and engine restarts after that.

#### How to Erase Self-Diagnostic Results

Before erasing DTC memory, start the engine and drive at 30 km/h (19 MPH) or more for approximately 1 minute. Check that ABS warning lamp turns OFF.

#### NOTE:

When 4WD warning lamp is ON with system malfunction of DTC "C1203", 4WD warning lamp may not turned OFF unless running the vehicle at 30 km/h (19 MPH) or more for a minute and check ABS warning lamp is turned OFF. Then turn ignition key OFF, and start engine again.

### DATA MONITOR MODE

Display Item List

×: Standard ▼: Optional Item

Monitor item (Unit)	SELECT MONITOR ITEM		Remarks
	ECU INPUT SIGNALS	MAIN SIGNALS	
FR RH SENSOR [km/h] or [mph]	×	×	Wheel speed calculated by front wheel sensor RH signal is displayed.
FR LH SENSOR [km/h] or [mph]	×	×	Wheel speed calculated by front wheel sensor LH signal is displayed.

# TROUBLE DIAGNOSIS

## < SERVICE INFORMATION >

Monitor item (Unit)	SELECT MONITOR ITEM		Remarks
	ECU INPUT SIGNALS	MAIN SIGNALS	
RR RH SENSOR [km/h] or [mph]	×	×	Wheel speed calculated by rear wheel sensor RH signal is displayed.
RR LH SENSOR [km/h] or [mph]	×	×	Wheel speed calculated by rear wheel sensor LH signal is displayed.
BATTERY VOLT [V]	▼	▼	Power supply voltage for AWD control unit
THRTL POS SEN [%]	▼	▼	Throttle opening status is displayed.
ETS SOLENOID [A]	▼	▼	Monitored value of current at AWD solenoid
STOP LAMP SW [ON/OFF]	▼	▼	Stop lamp switch signal status via CAN communication line is displayed.
ENG SPEED SIG [RUN/STOP]	▼	▼	Engine status is displayed.
ETS ACTUATOR [ON/OFF]	▼	▼	Operating condition of AWD actuator relay (integrated in AWD control unit) is displayed.
4WD WARN LAMP [ON/OFF]	▼	▼	Control status of AWD warning lamp is displayed.
4WD MODE SW [AUTO]	▼	▼	Mode switch is not equipped, but displayed.
4WD MODE MON [AUTO]	▼	▼	Control status of AWD is displayed.
DIS-TIRE MONI [mm]	▼	▼	Improper size tire installed condition is displayed.
P BRAKE SW [ON/OFF]	▼	▼	Parking switch signal status via CAN communication line is displayed.
Voltage [V]	▼	▼	The value measured by the voltage probe is displayed.
Frequency [Hz]	▼	▼	The value measured by the pulse probe is displayed.
DUTY-HI (high) [%]	▼	▼	
DUTY-LOW (low) [%]	▼	▼	
PLS WIDTH-HI [msec]	▼	▼	
PLS WIDTH-LOW [msec]	▼	▼	

## ACTIVE TEST MODE

### Description

Use this mode to determine and identify the details of a malfunction based on self-diagnostic results or data monitor. AWD control unit gives drive signal to actuator with receiving command from CONSULT-III to check operation of actuator.

### Test Item

Test item	Condition	Description
ETS S/V (Detects AWD solenoid)	<ul style="list-style-type: none"> <li>• Vehicle stopped</li> <li>• Engine running</li> <li>• No DTC detected</li> </ul>	<ul style="list-style-type: none"> <li>• Change command current value to AWD solenoid, and then change driving mode. (Monitor value is normal if it is within approximately <math>\pm 10\%</math> of command value.)</li> <li>Qu: Increase current value in increments of 0.20A</li> <li>Qd: Decrease current value in increments of 0.20A</li> <li>UP: Increase current value in increments of 0.02A</li> <li>DOWN: Decrease current value in increments of 0.02A</li> </ul>

### CAUTION:

**Do not continuously energize for a long time.**



# TROUBLE DIAGNOSIS FOR SYSTEM

< SERVICE INFORMATION >

## TROUBLE DIAGNOSIS FOR SYSTEM

### Power Supply Circuit for AWD Control Unit

INFOID:00000002955692

#### CONSULT-III REFERENCE VALUE IN DATA MONITOR MODE

Data are reference value.

Monitor item [Unit]	Condition	Display value (Approx.)
BATTERY VOLT [V]	Ignition switch: ON	Battery voltage

#### DIAGNOSTIC PROCEDURE

##### 1.CHECK POWER SUPPLY

1. Turn ignition switch "OFF".
2. Disconnect AWD control unit harness connector.
3. Turn ignition switch "ON". (Do not start engine.)
4. Check voltage between AWD control unit harness connector terminals and ground.

Connector	Terminal	Voltage (Approx.)
F109	7 - Ground	Battery voltage
	9 - Ground	

5. Turn ignition switch "OFF".
6. Check voltage between AWD control unit harness connector terminals and ground.

Connector	Terminal	Voltage (Approx.)
F109	7 - Ground	0V
	9 - Ground	Battery voltage

#### OK or NG

- OK >> GO TO 2.  
NG >> Check the following. If any items are damaged, repair or replace damaged parts.
- 10A fuse [No.33, located in the fuse block (J/B)]
  - 10A fuse [No.82, located in the IPDM E/R]
  - Harness for short or open between battery and AWD control unit harness connector terminal 9
  - Harness for short or open between ignition switch and AWD control unit harness connector terminal 7
  - Ignition switch. Refer to [PG-4](#).

##### 2.CHECK GROUND CIRCUIT

1. Turn ignition switch "OFF".
2. Disconnect AWD control unit harness connector.
3. Check continuity between AWD control unit harness connector F109 terminals 10, 11 and ground.

**Continuity should exist.**

Also check harness for short to ground and short to power.

#### OK or NG

- OK >> GO TO 3.  
NG >> Repair open circuit or short to ground or short to power in harness or connectors.

##### 3.CHECK DTC

Start engine.

Does AWD warning lamp turn OFF?

- YES >> **INSPECTION END**  
NO >> Perform the self-diagnosis, repair or replace damaged parts. Refer to [TF-22. "CONSULT-III Function \(ALL MODE AWD/4WD\)"](#).

# TROUBLE DIAGNOSIS FOR SYSTEM

< SERVICE INFORMATION >

## AWD Control Unit

INFOID:000000002955693

### DIAGNOSTIC PROCEDURE

- Check the following if “CONTROLLER FAILURE [C1201]” is displayed in self-diagnosis results of CONSULT-III.

#### 1.PERFORM SELF-DIAGNOSIS

##### With CONSULT-III

1. Turn ignition switch “ON”. (Do not start engine.)
2. Select “SELF-DIAG RESULTS” mode for “ALL MODE AWD/4WD” with CONSULT-III.
3. Touch “ERASE”.
4. Turn ignition switch “OFF” and wait at least 10 seconds.
5. Perform the self-diagnosis again.

Is the “CONTROLLER FAILURE [C1201]” displayed?

YES >> Replace AWD control unit. Refer to [TF-36](#).

NO >> **INSPECTION END**

## ABS System

INFOID:000000002955694

### DIAGNOSTIC PROCEDURE

- Check the following if “ABS SYSTEM [C1203]” is displayed in self-diagnosis results of CONSULT-III.

#### 1.CHECK DTC WITH ABS ACTUATOR AND ELECTRIC UNIT (CONTROL UNIT)

Perform self-diagnosis with ABS actuator and electric unit (control unit). Refer to [BRC-30. "CONSULT-III Function \(ABS\)"](#).

Is any malfunction detected by self-diagnosis?

YES >> Check the malfunctioning system.

NO >> GO TO 2.

#### 2.CHECK DTC AFTER DRIVING

1. Turn ignition switch “OFF”.
2. Start engine and drive vehicle at 30 km/h (19 MPH) for at least 1 minute.
3. Make sure that ABS warning lamp turns OFF.
4. Perform erase self-diagnosis results. Refer to [TF-22. "CONSULT-III Function \(ALL MODE AWD/4WD\)"](#).
5. Stop vehicle and turn ignition switch “OFF”.
6. Turn ignition switch “ON”.
7. Perform self-diagnosis.

Is the “ABS SYSTEM [C1203]” displayed?

YES >> GO TO 3.

NO >> **INSPECTION END**

#### 3.CHECK AWD CONTROL UNIT

Check AWD control unit input/output signal. Refer to [TF-21. "AWD Control Unit Input/Output Signal Reference Value"](#).

##### OK or NG

OK >> GO TO 4.

NG >> Check AWD control unit pin terminals for damage or loose connection with harness connector. If any items are damaged, repair or replace damaged parts.

#### 4.CHECK DTC

Perform the self-diagnosis, after driving a vehicle for a while.

##### OK or NG

OK >> **INSPECTION END**

NG >> Perform self-diagnosis with ABS actuator and electric unit (control unit) again. Refer to [BRC-30. "CONSULT-III Function \(ABS\)"](#).

# TROUBLE DIAGNOSIS FOR SYSTEM

< SERVICE INFORMATION >

## AWD Solenoid

INFOID:00000002955695

### CONSULT-III REFERENCE VALUE IN DATA MONITOR MODE

Data are reference value.

Monitor item [Unit]	Condition	Display value
ETS SOLENOID [A]	Engine running	At idle speed
		When depressing accelerator pedal
		Approx. 0.000A
		Approx. 0.000 - 0.500A*

\*: The values are changed by throttle opening and engine speed.

### DIAGNOSTIC PROCEDURE

- Check the following if "4WD SOLENOID [C1204]" is displayed in self-diagnosis results of CONSULT-III.

#### 1. CHECK AWD SOLENOID SIGNAL

##### With CONSULT-III

1. Start engine.
2. Select "DATA MONITOR" mode for "ALL MODE AWD/4WD" with CONSULT-III.
3. Read out the value of "ETS SOLENOID".

Condition	Display value
Engine running	At idle speed
	When depressing accelerator pedal
	Approx. 0.000A
	Approx. 0.000 - 0.500A*

\*: The values are changed by throttle opening and engine speed.

#### OK or NG

- OK >> GO TO 6.
- NG >> GO TO 2.

#### 2. CHECK POWER SUPPLY

1. Turn ignition switch "OFF".
2. Disconnect AWD control unit harness connector.
3. Turn ignition switch "ON". (Do not start engine.)
4. Check voltage between AWD control unit harness connector terminal 9 and ground.

Connector	Terminal	Voltage (Approx.)
F109	9 - Ground	Battery voltage

#### OK or NG

- OK >> GO TO 3.
- NG >> Check the following. If any items are damaged, repair or replace damaged parts.
  - 10A fuse [No. 33, located in the fuse block (J/B)]
  - Harness for short or open between battery and AWD control unit harness connector terminal 9

#### 3. CHECK AWD SOLENOID CIRCUIT

1. Turn ignition switch "OFF".
2. Disconnect AWD control unit harness connector.
3. Check resistance between AWD control unit harness connector terminals 1 and 2.

Connector	Terminal	Resistance (Approx.)
F109	1 - 2 (Ground)	2.45 Ω

#### OK or NG

- OK >> GO TO 6.
- NG >> GO TO 4.

#### 4. CHECK AWD SOLENOID

1. Turn ignition switch "OFF".

# TROUBLE DIAGNOSIS FOR SYSTEM

## < SERVICE INFORMATION >

2. Disconnect transfer assembly harness connector.
3. Check resistance between transfer assembly harness connector F43 terminals 1 and 2.

**1 - 2 : Approx. 2.45Ω**

### OK or NG

- OK >> GO TO 5.  
NG >> AWD solenoid is malfunctioning. Replace electric controlled coupling. Refer to [TF-41, "Disassembly and Assembly"](#).

## 5. CHECK HARNESS BETWEEN AWD CONTROL UNIT AND AWD SOLENOID

1. Turn ignition switch "OFF".
2. Disconnect AWD control unit harness connector and transfer assembly harness connector.
3. Check continuity between the following terminals.
  - AWD control unit harness connector F109 terminal 1 and transfer assembly harness connector F43 terminal 1.
  - AWD control unit harness connector F109 terminal 2 and transfer assembly harness connector F43 terminal 2.

**1 - 1 : Continuity should exist.**

**2 - 2 : Continuity should exist.**

Also check harness for short to ground and short to power.

### OK or NG

- OK >> GO TO 6.  
NG >> Repair or replace damaged parts.

## 6. CHECK AWD CONTROL UNIT

Check AWD control unit input/output signal. Refer to [TF-21, "AWD Control Unit Input/Output Signal Reference Value"](#).

### OK or NG

- OK >> GO TO 7.  
NG >> Check AWD control unit pin terminals for damage or loose connection with harness connector. If any items are damaged, repair or replace damaged parts.

## 7. CHECK DTC

Perform the self-diagnosis, after driving a vehicle for a while.

### OK or NG

- OK >> **INSPECTION END**  
NG >> Replace AWD control unit.

## COMPONENT INSPECTION

1. Turn ignition switch "OFF".
2. Disconnect transfer assembly harness connector.
3. Check resistance between transfer assembly harness connector F43 terminals 1 and 2.

**1 - 2 : Approx. 2.45Ω**

4. If NG, replace electric controlled coupling. Refer to [TF-41, "Disassembly and Assembly"](#).

## AWD Actuator Relay

INFOID:000000002955696

## CONSULT-III REFERENCE VALUE IN DATA MONITOR MODE

Data are reference value.

Monitor item	Condition	Display value
ETS ACTUATOR [ON/OFF]	Engine stopped (Ignition switch: ON)	Off
	Engine running	On

## DIAGNOSTIC PROCEDURE

# TROUBLE DIAGNOSIS FOR SYSTEM

## < SERVICE INFORMATION >

- Check the following if “4WD ACTUATOR RLY [C1205]” is displayed in self-diagnosis results of CONSULT-III.

### 1.CHECK AWD SOLENOID SYSTEM

Perform self-diagnosis. Refer to [TF-22, "CONSULT-III Function \(ALL MODE AWD/4WD\)"](#).

Is the “4WD SOLENOID [C1204]” displayed?

- YES >> Perform trouble diagnosis for AWD solenoid. Refer to [TF-27, "AWD Solenoid"](#).
- NO >> GO TO 2.

### 2.CHECK AWD ACTUATOR RELAY SIGNAL

#### With CONSULT-III

1. Turn ignition switch “ON”. (Do not start engine.)
2. Select “DATA MONITOR” mode for “ALL MODE AWD/4WD” with CONSULT-III.
3. Start engine and read out ON/OFF signal of “ETS ACTUATOR”.

Monitor item	Condition	Display value
ETS ACTUATOR	Engine stopped (Ignition switch: ON)	Off
	Engine running	On

#### OK or NG

- OK >> GO TO 4.
- NG >> GO TO 3.

### 3.CHECK AWD CONTROL UNIT

Check AWD control unit input/output signal. Refer to [TF-21, "AWD Control Unit Input/Output Signal Reference Value"](#).

#### OK or NG

- OK >> GO TO 4.
- NG >> Check AWD control unit pin terminals for damage or loose connection with harness connector. If any items are damaged, repair or replace damaged parts.

### 4.CHECK DTC

Perform the self-diagnosis, after driving a vehicle for a while.

#### OK or NG

- OK >> **INSPECTION END**
- NG >> Replace AWD control unit.

## Engine Control Signal

INFOID:000000002955697

### DIAGNOSTIC PROCEDURE

- Check the following if “ECM SIGNAL 1 [C1210]” is displayed in self-diagnosis results of CONSULT-III.

### 1.CHECK DTC WITH ECM

Perform self-diagnosis with ECM. Refer to [EC-55, "Emission-Related Diagnostic Information"](#) (VQ35DE models), [EC-677, "Emission-Related Diagnostic Information"](#) (VK45DE models).

Is any malfunction detected by self-diagnosis?

- YES >> Check the malfunctioning system.
- NO >> GO TO 2.

### 2.CHECK AWD CONTROL UNIT

Check AWD control unit input/output signal. Refer to [TF-21, "AWD Control Unit Input/Output Signal Reference Value"](#).

#### OK or NG

- OK >> GO TO 3.
- NG >> Check AWD control unit pin terminals for damage or loose connection with harness connector. If any items are damaged, repair or replace damaged parts.

### 3.CHECK DTC

# TROUBLE DIAGNOSIS FOR SYSTEM

## < SERVICE INFORMATION >

---

Perform the self-diagnosis, after driving a vehicle for a while.

### OK or NG

OK >> **INSPECTION END**

NG >> Perform self-diagnosis with ECM again. Refer to [EC-55, "Emission-Related Diagnostic Information"](#) (VQ35DE models), [EC-677, "Emission-Related Diagnostic Information"](#) (VK45DE models).

## CAN Communication Line

INFOID:000000002955698

### DIAGNOSTIC PROCEDURE

- Check the following if "CAN COMM CIRCUIT [U1000]" is detected in self-diagnosis results of CONSULT-III.

#### **1**.CHECK CAN COMMUNICATION CIRCUIT

---

##### **With CONSULT-III**

1. Turn ignition switch "ON" and start engine.
2. Select "SELF-DIAG RESULTS" mode for "ALL MODE AWD/4WD" with in CONSULT-III.
3. Perform the self-diagnosis.

#### Is the "CAN COMM CIRCUIT [U1000]" displayed?

- YES >> Print out CONSULT-III screen and go to [LAN-29, "CAN System Specification Chart"](#).
- NO >> **INSPECTION END**

# TROUBLE DIAGNOSIS FOR SYMPTOMS

< SERVICE INFORMATION >

## TROUBLE DIAGNOSIS FOR SYMPTOMS

### AWD Warning Lamp Does Not Turn ON When the Ignition Switch Is Turned to ON

INFOID:000000002955699

#### DIAGNOSTIC PROCEDURE

#### 1. CHECK SYSTEM FOR CAN COMMUNICATION LINE

Perform self-diagnosis. Refer to [TF-22, "CONSULT-III Function \(ALL MODE AWD/4WD\)"](#).

Is the "CAN COMM CIRCUIT [U1000]" displayed?

YES >> Perform trouble diagnosis for CAN communication line. Refer to [TF-30, "CAN Communication Line"](#).

NO >> GO TO 2.

#### 2. CHECK AWD CONTROL UNIT

Check AWD control unit input/output signal. Refer to [TF-21, "AWD Control Unit Input/Output Signal Reference Value"](#).

OK or NG

OK >> GO TO 3.

NG >> Check AWD control unit pin terminals for damage or loose connection with harness connector. If any items are damaged, repair or replace damaged parts.

#### 3. CHECK OUTPUT SIGNAL WITH UNIFIED METER AND A/C AMP.

 With CONSULT-III

1. Turn ignition switch "ON". (Do not start engine.)
2. Select "DATA MONITOR" mode for "METER A/C AMP" with CONSULT-III.
3. Start the engine, and then make sure that "4WD W/L" display turns from "ON" to "OFF" after several seconds.

Monitor item	Condition	Display value
4WD W/L	Ignition switch ON	On
	Start engine (after several seconds)	Off

OK or NG

OK >> GO TO 4.

NG >> Perform trouble diagnosis for combination meter. Refer to [DI-18, "Trouble Diagnosis"](#).

#### 4. SYMPTOM CHECK

Check again.

OK or NG

OK >> **INSPECTION END**

NG >> Replace unified meter control unit assembly. Refer to [DI-25, "Disassembly and Assembly of Combination Meter"](#).

### AWD Warning Lamp Does Not Turn OFF Several Seconds after Engine Started

INFOID:000000002955700

#### DIAGNOSTIC PROCEDURE

#### 1. CHECK SELF-DIAGNOSTIC RESULTS

Perform self-diagnosis. Refer to [TF-22, "CONSULT-III Function \(ALL MODE AWD/4WD\)"](#).

Is any malfunction detected by self-diagnosis?

YES >> Check the malfunctioning system.

NO >> GO TO 2.

#### 2. CHECK AWD CONTROL UNIT POWER SUPPLY CIRCUIT

1. Turn ignition switch "OFF".

# TROUBLE DIAGNOSIS FOR SYMPTOMS

## < SERVICE INFORMATION >

2. Disconnect AWD control unit harness connector.
3. Turn ignition switch "ON". (Do not start engine.)
4. Check voltage between AWD control unit harness connector terminals and ground.

Connector	Terminal	Voltage (Approx.)
F109	7 - Ground	Battery voltage
	9 - Ground	

5. Turn ignition switch "OFF".
6. Check voltage between AWD control unit harness connector terminals and ground.

Connector	Terminal	Voltage (Approx.)
F109	7 - Ground	0V
	9 - Ground	Battery voltage

### OK or NG

OK >> GO TO 3.

- NG >> Check the following. If any items are damaged, repair or replace damaged parts.
- 10A fuse [No.33, located in the fuse block (J/B)]
  - 10A fuse [No.82, located in the IPDM E/R]
  - Harness for short or open between battery and AWD control unit harness connector terminal 9
  - Harness for short or open between ignition switch and AWD control unit harness connector terminal 7
  - Ignition switch. Refer to [BL-103. "Check Ignition Switch Position"](#).

## 3.CHECK AWD CONTROL UNIT GROUND CIRCUIT

1. Turn ignition switch "OFF".
2. Disconnect AWD control unit harness connector.
3. Check continuity between AWD control unit harness connector F109 terminals 10, 11 and ground.

**Continuity should exist.**

Also check harness for short to ground and short to power.

### OK or NG

OK >> GO TO 4.

NG >> Repair open circuit or short to ground or short to power in harness or connectors.

## 4.CHECK AWD CONTROL UNIT

Check AWD control unit input/output signal. Refer to [TF-21. "AWD Control Unit Input/Output Signal Reference Value"](#).

### OK or NG

OK >> GO TO 5.

NG >> Check AWD control unit pin terminals for damage or loose connection with harness connector. If any items are damaged, repair or replace damaged parts.

## 5.CHECK OUTPUT SIGNAL WITH UNIFIED METER AND A/C AMP.

### With CONSULT-III

1. Turn ignition switch "ON". (Do not start engine.)
2. Select "DATA MONITOR" mode for "METER A/C AMP" with CONSULT-III.
3. Start the engine, and then make sure that "4WD W/L" display turns from "ON" to "OFF" after several seconds.

Monitor item	Condition	Display value
4WD W/L	Ignition switch ON	On
	Start engine (after several seconds)	Off

### OK or NG



# TROUBLE DIAGNOSIS FOR SYMPTOMS

## < SERVICE INFORMATION >

---

- OK >> GO TO 6.  
NG >> Perform trouble diagnosis for combination meter. Refer to [DI-18, "Trouble Diagnosis"](#).

## 6. SYMPTOM CHECK

---

Check again.

### OK or NG

- OK >> **INSPECTION END**  
NG >> Replace unified meter control unit assembly. Refer to [DI-25, "Disassembly and Assembly of Combination Meter"](#).

Heavy Tight-Corner Braking Symptom Occurs When the Vehicle Is Driven and the Steering Wheel Is Turned Fully to Either Side after the Engine Is Started

INFOID:000000002955701

### **NOTE:**

Light tight-corner braking symptom may occur depending on driving conditions. This is not malfunction.

## DIAGNOSTIC PROCEDURE

### 1. CHECK SYSTEM FOR CAN COMMUNICATION LINE

---

Perform self-diagnosis. Refer to [TF-22, "CONSULT-III Function \(ALL MODE AWD/4WD\)"](#).

Is the "CAN COMM CIRCUIT [U1000]" displayed?

- YES >> Perform trouble diagnosis for CAN communication line. Refer to [TF-30, "CAN Communication Line"](#).  
NO >> GO TO 2.

### 2. CHECK ACCELERATOR PEDAL POSITION SIGNAL CIRCUIT

---

Perform self-diagnosis for ECM. Refer to [EC-55, "Emission-Related Diagnostic Information"](#) (VQ35DE models), [EC-677, "Emission-Related Diagnostic Information"](#) (VK45DE models).

Is any malfunction detected by self-diagnosis?

- YES >> Check the malfunctioning system.  
NO >> GO TO 3.

### 3. CHECK SYSTEM FOR AWD SOLENOID

---

Perform trouble diagnosis for AWD solenoid system. Refer to [TF-27, "AWD Solenoid"](#).

### OK or NG

- OK >> GO TO 4.  
NG >> Repair or replace damaged parts.

### 4. CHECK ELECTRIC CONTROLLED COUPLING

---

1. Turn ignition switch "OFF".
2. Set the selector lever to "N" (neutral) position and disengage the parking brake.
3. Lift up the vehicle.
4. Rotate the rear propeller shaft by hand.
5. Hold front propeller shaft lightly.

Does front propeller shaft rotate?

- YES >> Replace electric controlled coupling for mechanical malfunction (clutch sticking etc.). Refer to [TF-41, "Disassembly and Assembly"](#).  
NO >> GO TO 5.

## 5. SYMPTOM CHECK

---

Check again.

### OK or NG

- OK >> **INSPECTION END**  
NG >> GO TO 6.

## 6. CHECK AWD CONTROL UNIT

---

# TROUBLE DIAGNOSIS FOR SYMPTOMS

## < SERVICE INFORMATION >

Check AWD control unit input/output signal. Refer to [TF-21, "AWD Control Unit Input/Output Signal Reference Value"](#).

### OK or NG

OK >> **INSPECTION END**

NG >> Check AWD control unit pin terminals for damage or loose connection with harness connector. If any items are damaged, repair or replace damaged parts.

## Vehicle Does Not Enter AWD Mode Even Though AWD Warning Lamp Turned to OFF

INFOID:000000002955702

### DIAGNOSTIC PROCEDURE

#### 1. CHECK AWD WARNING LAMP

Turn ignition switch "ON". (Do not start engine.)

##### Does AWD warning lamp turn on?

YES >> GO TO 2.

NO >> Go to [TF-31, "AWD Warning Lamp Does Not Turn ON When the Ignition Switch Is Turned to ON"](#).

#### 2. CHECK SYSTEM FOR CAN COMMUNICATION LINE

Perform self-diagnosis. Refer to [TF-22, "CONSULT-III Function \(ALL MODE AWD/4WD\)"](#).

##### Is the "CAN COMM CIRCUIT [U1000]" displayed?

YES >> Perform trouble diagnosis for CAN communication line. Refer to [TF-30, "CAN Communication Line"](#).

NO >> GO TO 3.

#### 3. CHECK AWD SOLENOID

Check AWD solenoid. Refer to [TF-27, "AWD Solenoid"](#).

### OK or NG

OK >> GO TO 4.

NG >> Replace electric controlled coupling for malfunction of AWD solenoid. Refer to [TF-41, "Disassembly and Assembly"](#).

#### 4. CHECK AWD CONTROL UNIT

Check AWD control unit input/output signal. Refer to [TF-21, "AWD Control Unit Input/Output Signal Reference Value"](#).

### OK or NG

OK >> GO TO 5.

NG >> Check AWD control unit pin terminals for damage or loose connection with harness connector. If any items are damaged, repair or replace damaged parts.

#### 5. SYMPTOM CHECK

Check again.

### OK or NG

OK >> **INSPECTION END**

NG >> Replace electric controlled coupling for mechanical malfunction (mechanical engagement of clutch is not possible.). Refer to [TF-41, "Disassembly and Assembly"](#).

## While Driving, AWD Warning Lamp Flashes Rapidly (When Flashing in Approx. 1 Minute and Then Turning OFF)

INFOID:000000002955703

### NOTE:

#### **Rapid flashing: 2 times/second**

This symptom protects drivetrain parts when a heavy load is applied to the electric controlled coupling and multiple disc clutch temperature increases. Also, optional distribution of torque sometimes becomes rigid before lamp flashes rapidly. Both cases are not malfunction.

When this symptom occurs, stop vehicle and allow it to idle for some times. Flashing will stop and system will be restored.

# TROUBLE DIAGNOSIS FOR SYMPTOMS

< SERVICE INFORMATION >

While Driving, AWD Warning Lamp Flashes Slowly (When Continuing to Flash until Turning Ignition Switch OFF)

INFOID:000000002955704

A

## NOTE:

**Slow flashing: 1 time/2 seconds**

B

## DIAGNOSTIC PROCEDURE

### 1. CHECK TIRE

C

Check the following.

- Tire pressure
- Wear condition
- Longitudinal tire size (There is no difference between longitudinal tires.)

TF

#### OK or NG

OK >> GO TO 2.

E

NG >> Drive at vehicle speed of 20 km/h (12 MPH) or more for 5 seconds or more after repairing or replacing damaged parts. (Initialize improper size tire information.)

### 2. CHECK INPUT SIGNAL OF TIRE DIAMETER

F

#### With CONSULT-III

1. Start engine.
2. Drive at 20 km/h (12 MPH) or more for approx. 200 seconds.
3. Select "DATA MONITOR" mode for "ALL MODE AWD/4WD" with CONSULT-III.
4. Check monitor "DIS-TIRE MONI".

G

#### Display of "DIS-TIRE MONI"

H

"0-4mm">>**INSPECTION END**

Except for "0-4mm">>GO TO 3.

I

### 3. CHECK AWD CONTROL UNIT

Check AWD control unit input/output signal. Refer to [TF-21, "AWD Control Unit Input/Output Signal Reference Value"](#).

J

#### OK or NG

OK >> GO TO 4.

NG >> Check AWD control unit pin terminals for damage or loose connection with harness connector. If any items are damaged, repair or replace damaged parts.

K

### 4. SYMPTOM CHECK

Check again.

L

#### OK or NG

OK >> **INSPECTION END**

M

NG >> Replace AWD control unit.

N

O

P

# AWD CONTROL UNIT

< SERVICE INFORMATION >

## AWD CONTROL UNIT

### Removal and Installation

INFOID:000000002955705

#### REMOVAL

1. Remove the dash side finisher. Refer to [EI-48](#).
2. Disconnect AWD control unit connector.
3. Remove the AWD control unit.

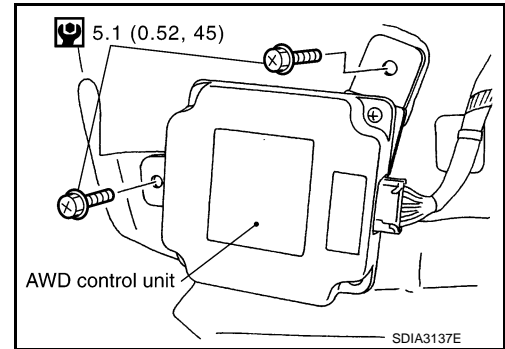

#### INSTALLATION

Install in the reverse order of removal.

# FRONT OIL SEAL

< SERVICE INFORMATION >

## FRONT OIL SEAL

### Removal and Installation

INFOID:00000002955706

#### REMOVAL

1. Remove the drain plug to drain the transfer fluid. Refer to [TF-10, "Replacement"](#).
2. Remove the front propeller shaft. Refer to [PR-4](#).
3. Remove front oil seal using a flat-bladed screwdriver.

**CAUTION:**

**Be careful not to damage the front case and front drive shaft.**

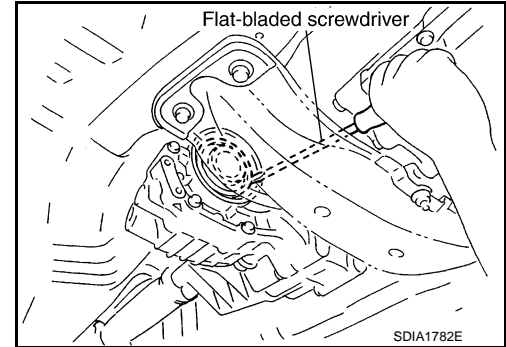

#### INSTALLATION

1. Apply ATF to front oil seal, install it with a drift until the end face of front case.

**Tool number** : ST27862000 ( — )

**CAUTION:**

- Do not reuse front oil seal.
- When installing, do not incline front oil seal.

2. Install front propeller shaft. Refer to [PR-4](#).
3. Install transfer fluid, check fluid level and for fluid leakage. Refer to [TF-10, "Inspection"](#).

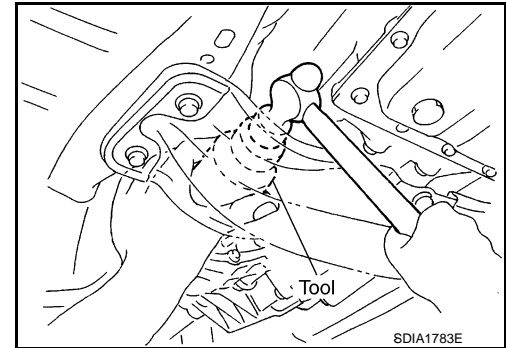

A  
B  
C  
TF  
E  
F  
G  
H  
I  
J  
K  
L  
M  
N  
O  
P

# REAR OIL SEAL

< SERVICE INFORMATION >

## REAR OIL SEAL

### Removal and Installation

INFOID:00000002955707

#### REMOVAL

1. Remove the rear propeller shaft. Refer to [PR-7](#).
2. Remove self-lock nut of companion flange using a flange wrench.

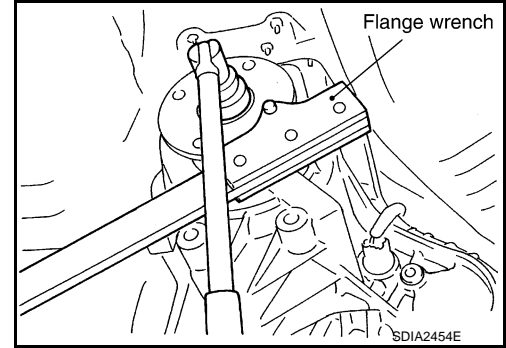

3. Put matching mark on the end of the mainshaft. The mark should be in line with the mark on the companion flange.

**CAUTION:**

**For matching mark, use paint. Do not damage mainshaft.**

**NOTE:**

The figure shows VQ35DE models.

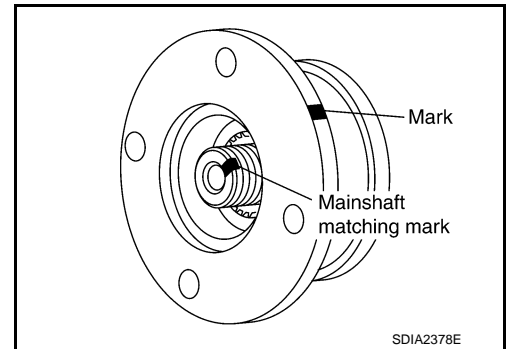

4. Remove companion flange using pullers.  
**CAUTION:**  
**Be careful not to damage the companion flange.**
  - VQ35DE models

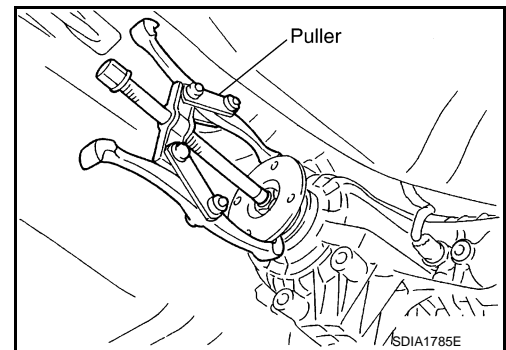

- VK45DE models

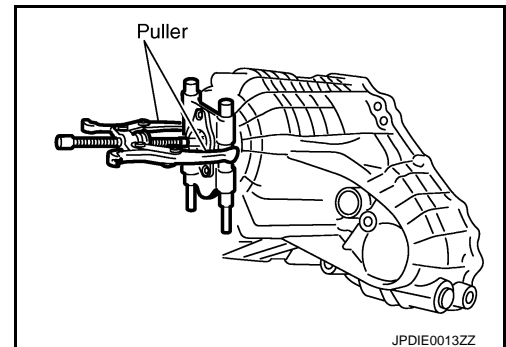

# REAR OIL SEAL

## < SERVICE INFORMATION >

- Remove the rear oil seal using the puller.

**Tool number** : KV381054S0 (J-34286)

**CAUTION:**

Be careful not to damage the rear case.

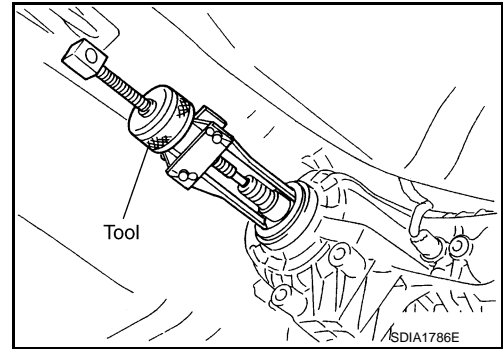

## INSTALLATION

- Apply ATF to rear oil seal, install it with a drifts.

**Dimension A** : 6.7 - 7.3 mm (0.264 - 0.287 in)

**Tool number A:** ST30720000 (J-25405)

**Tool number B:** KV40104830 ( — )

**CAUTION:**

- Do not reuse rear oil seal.
- When installing, do not incline rear oil seal.

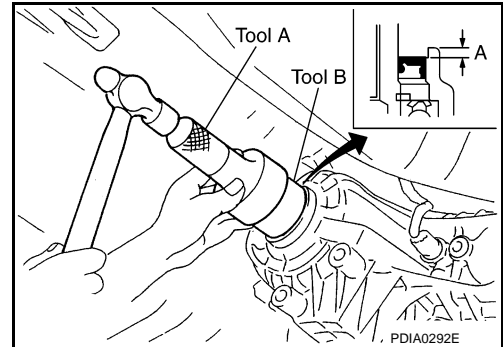

- Align the matching mark of mainshaft with the mark of companion flange, then install the companion flange.

**NOTE:**

The figure shows VQ35DE models.

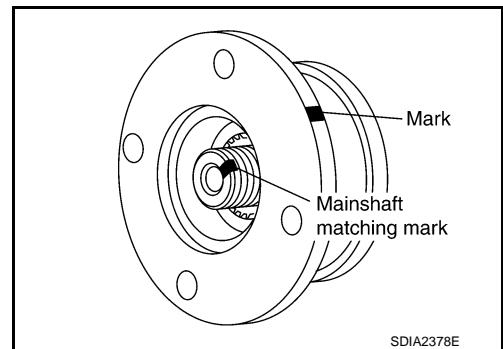

- Using a flange wrench, install the self-lock nut of companion flange and tighten to the specified torque. Refer to [TF-41, "Disassembly and Assembly"](#).

**CAUTION:**

Do not reuse self-lock nut.

- Install the rear propeller shaft. Refer to [PR-7](#).
- Check fluid level. Refer to [TF-10, "Inspection"](#).

**NOTE:**

The figure shows VQ35DE models.

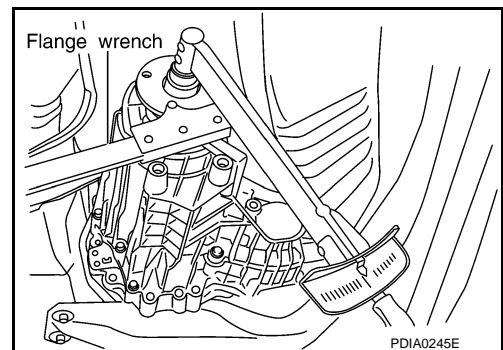

# AIR BREATHER HOSE

< SERVICE INFORMATION >

## AIR BREATHER HOSE

### Removal and Installation

INFOID:000000002955708

Refer to the figure for air breather hose removal and installation information.

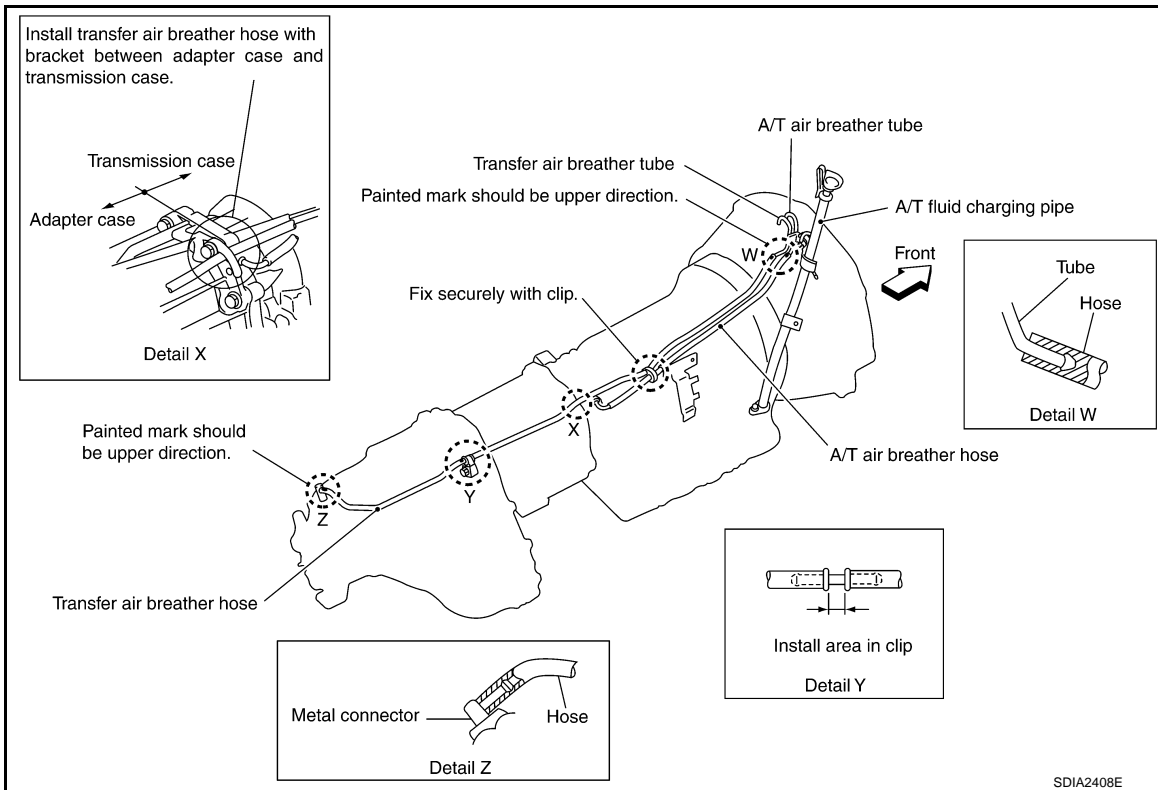

#### CAUTION:

- Make sure there are no pinched or restricted areas on the air breather hose caused by bending or winding when installing it.
- Be sure to insert air breather hose to transfer tube (metal connector) until hose end reaches the tube's base and another hose end reaches the tube bend R portion of A/T fluid charging pipe.



# TRANSFER ASSEMBLY

< SERVICE INFORMATION >

## TRANSFER ASSEMBLY

### Removal and Installation

INFOID:000000002955709

#### REMOVAL

1. Remove exhaust front tube with power tool. Refer to [EX-3. "Component"](#) (VQ35DE models), [EX-5. "Component"](#) (VK45DE models).
2. Remove front and rear propeller shaft. Refer to [PR-4](#) and [PR-7](#).
3. Disconnect transfer assembly harness connector and separate harness from transfer assembly.
4. Remove air breather hose. Refer to [TF-40](#).
5. Remove control rod. Refer to [AT-201. "Control Rod Removal and Installation"](#).
6. Support transfer assembly and transmission assembly with a jack.
7. Remove rear engine mounting member and engine mounting insulator with power tool. Refer to [EM-118. "AWD : Component"](#) (VQ35DE models), [EM-245. "AWD : Component"](#) (VK45DE models).
8. Lower jack to the position where the top transfer mounting bolts can be removed.
9. Remove transfer mounting bolts with power tool and separate transfer from transmission.

**CAUTION:**

**Secure transfer assembly and transmission assembly to a jack.**

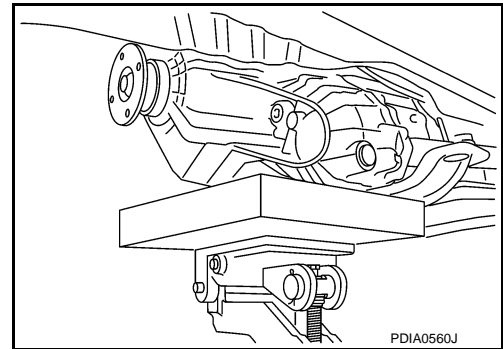

#### INSTALLATION

Note the following, and install in the reverse order of removal.

- When installing the transfer to the transmission, install the mounting bolts following the standard below.

Bolt No.	1	2	3	4
Quantity	4	3	2	1
Bolt length "ℓ" mm (in)	75 (2.95)	45 (1.77)	40 (1.57)	30 (1.18)
Tightening torque N·m (kg·m, ft·lb)	37 (3.8, 27)			

- After the installation, check the fluid level, fluid leakage and the A/T positions. Refer to [TF-10. "Inspection"](#), [AT-202. "Adjustment of A/T Position"](#).

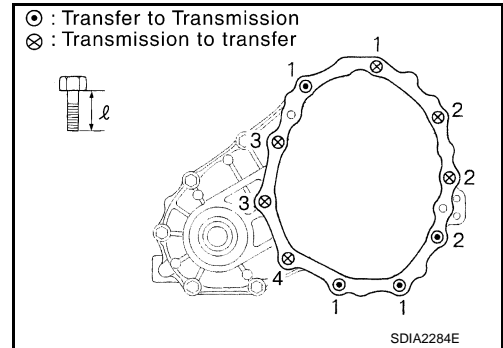

### Disassembly and Assembly

INFOID:000000002955710

#### COMPONENTS

# TRANSFER ASSEMBLY

< SERVICE INFORMATION >

VQ35DE models

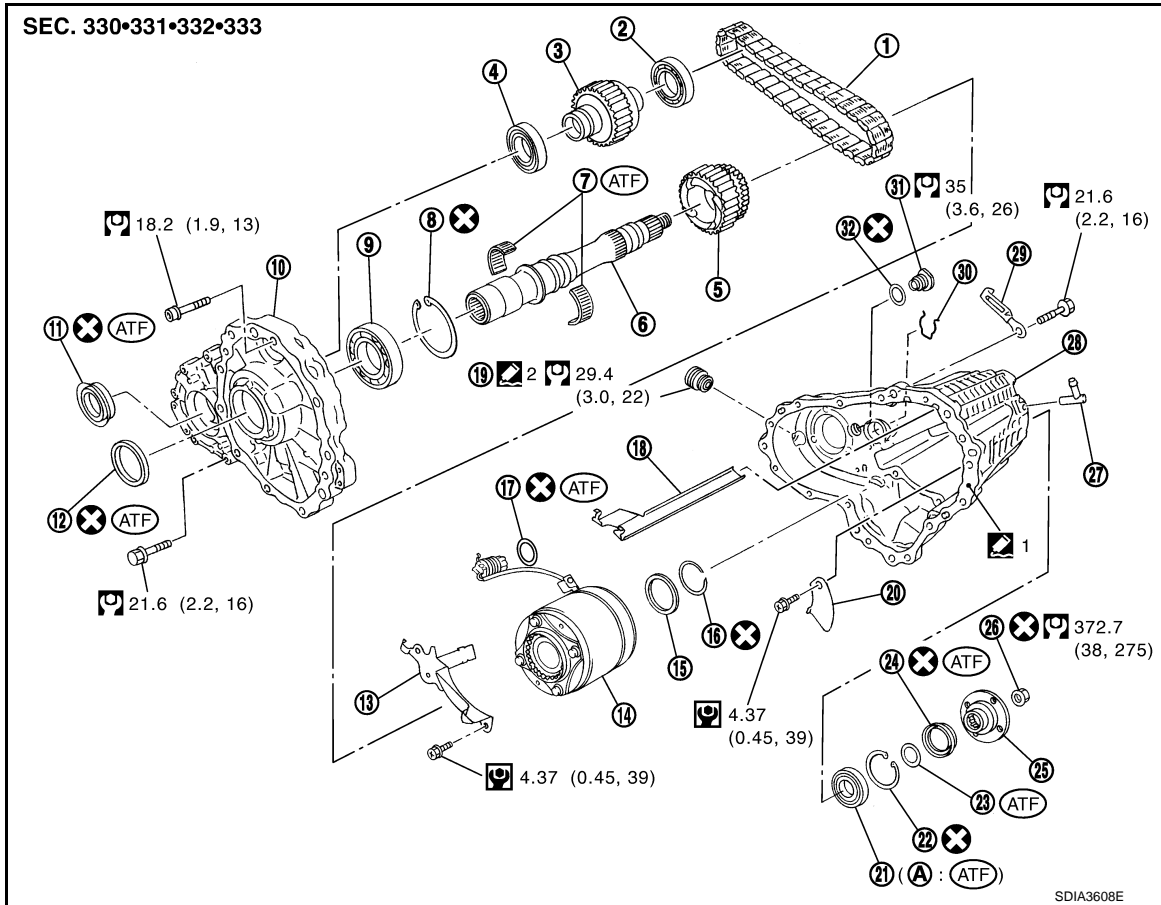

- |                                    |                                   |                        |
|------------------------------------|-----------------------------------|------------------------|
| 1. Drive chain                     | 2. Front drive shaft rear bearing | 3. Front drive shaft   |
| 4. Front drive shaft front bearing | 5. Sprocket                       | 6. Mainshaft           |
| 7. Needle bearing                  | 8. Snap ring                      | 9. Mainshaft bearing   |
| 10. Front case                     | 11. Front oil seal                | 12. Mainshaft oil seal |
| 13. Oil cover                      | 14. Electric controlled coupling  | 15. Spacer             |
| 16. Snap ring                      | 17. O-ring                        | 18. Oil gutter         |
| 19. Drain plug                     | 20. Baffle plate                  | 21. Rear bearing       |
| 22. Snap ring                      | 23. Spacer                        | 24. Rear oil seal      |
| 25. Companion flange               | 26. Self-lock nut                 | 27. Breather tube      |
| 28. Rear case                      | 29. Harness bracket               | 30. Retainer           |
| 31. Filler plug                    | 32. Gasket                        |                        |

A: Inside

1: Apply Genuine Anaerobic Liquid Gasket or equivalent. Refer to [GI-44, "Recommended Chemical Product and Sealant"](#).

2: Apply Genuine Silicone RTV or equivalent. Refer to [GI-44, "Recommended Chemical Product and Sealant"](#).

Refer to [GI-9, "Component"](#) for symbols not described on the above.

# TRANSFER ASSEMBLY

< SERVICE INFORMATION >

VK45DE models

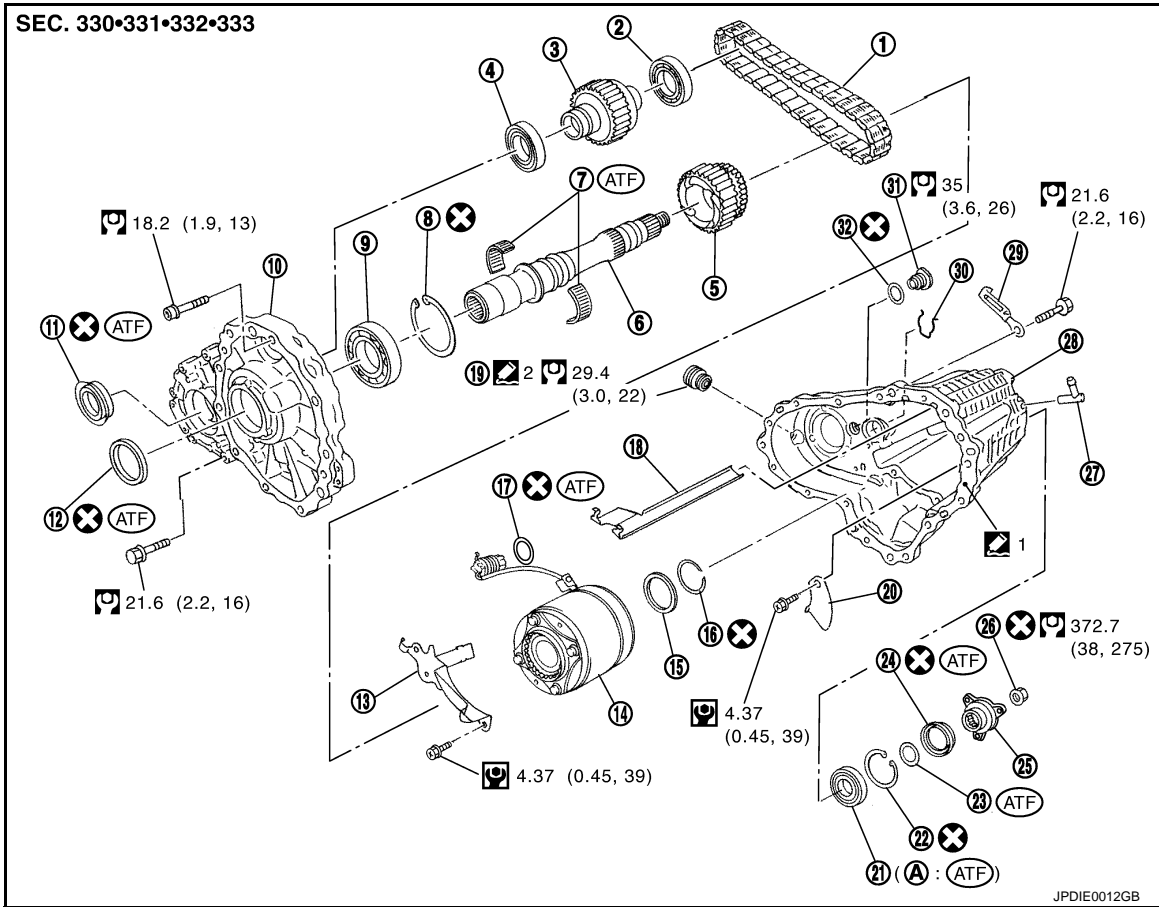

- |                                    |                                   |                        |
|------------------------------------|-----------------------------------|------------------------|
| 1. Drive chain                     | 2. Front drive shaft rear bearing | 3. Front drive shaft   |
| 4. Front drive shaft front bearing | 5. Sprocket                       | 6. Mainshaft           |
| 7. Needle bearing                  | 8. Snap ring                      | 9. Mainshaft bearing   |
| 10. Front case                     | 11. Front oil seal                | 12. Mainshaft oil seal |
| 13. Oil cover                      | 14. Electric controlled coupling  | 15. Spacer             |
| 16. Snap ring                      | 17. O-ring                        | 18. Oil gutter         |
| 19. Drain plug                     | 20. Baffle plate                  | 21. Rear bearing       |
| 22. Snap ring                      | 23. Spacer                        | 24. Rear oil seal      |
| 25. Companion flange               | 26. Self-lock nut                 | 27. Breather tube      |
| 28. Rear case                      | 29. Harness bracket               | 30. Retainer           |
| 31. Filler plug                    | 32. Gasket                        |                        |

A: Inside

1: Apply Genuine Anaerobic Liquid Gasket or equivalent. Refer to [GI-44, "Recommended Chemical Product and Sealant"](#).

2: Apply Genuine Silicone RTV or equivalent. Refer to [GI-44, "Recommended Chemical Product and Sealant"](#).

Refer to [GI-9, "Component"](#) for symbols not described on the above.

## DISASSEMBLY

### Front Case and Rear Case

1. Remove drain plug and filler plug.

## TRANSFER ASSEMBLY

### < SERVICE INFORMATION >

2. Remove mainshaft oil seal from front case, using a flat-bladed screwdriver.

**CAUTION:**

**Be careful not to damage the front case and mainshaft.**

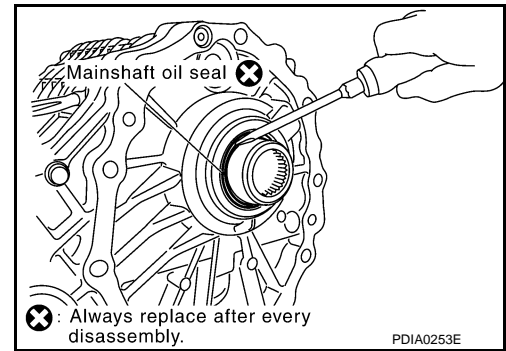

3. Remove front oil seal from front case, using a flat-bladed screwdriver.

**CAUTION:**

**Be careful not to damage the front case and front drive shaft.**

4. Remove self-lock nut.

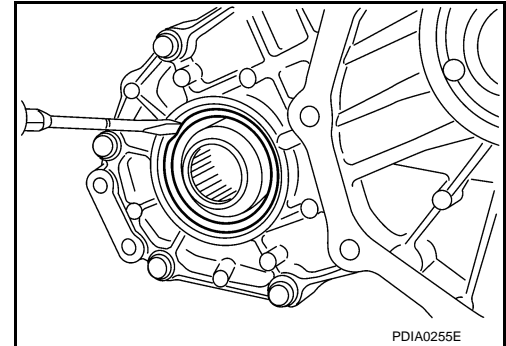

5. Put a matching mark on the end of mainshaft. The mark should be in line with the mark on the companion flange.

**CAUTION:**

**For matching mark, use paint. Do not damage mainshaft.**

**NOTE:**

The figure shows VQ35DE models.

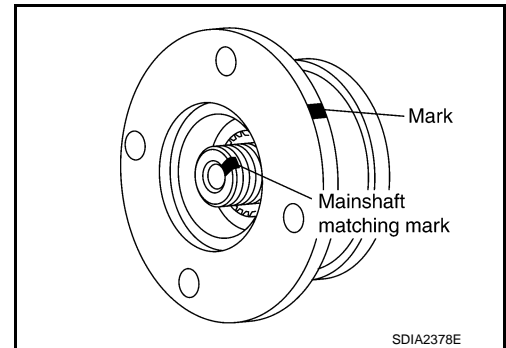

6. Remove companion flange, using a puller.

**CAUTION:**

**Be careful not to damage the companion flange.**

- VQ35DE models

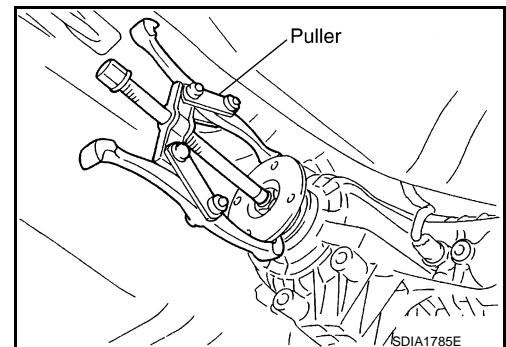

# TRANSFER ASSEMBLY

## < SERVICE INFORMATION >

- VK45DE models

7. Remove rear oil seal from rear case, using the puller.

**Tool number** : KV381054S0 (J-34286)

**CAUTION:**  
Be careful not to damage the rear case.

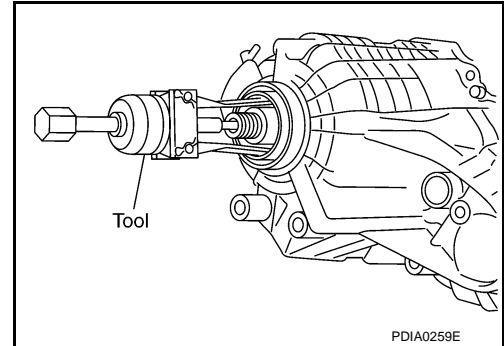
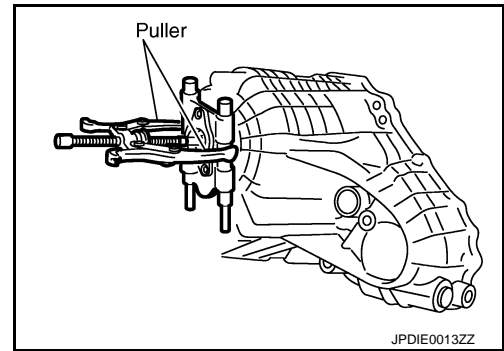

8. Remove spacer from mainshaft.

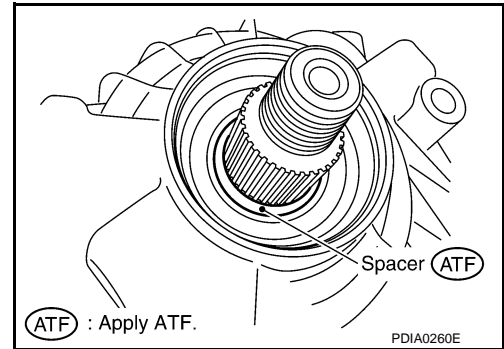

9. Remove front case and rear case fixing bolts, then remove harness bracket.

Bolts symbol	Quantity	Bolt length "ℓ" mm (in)
A	11	42 (1.65)
B	1	162 (6.38)
C	1	97 (3.82)
TORX bolt	1	40 (1.57)

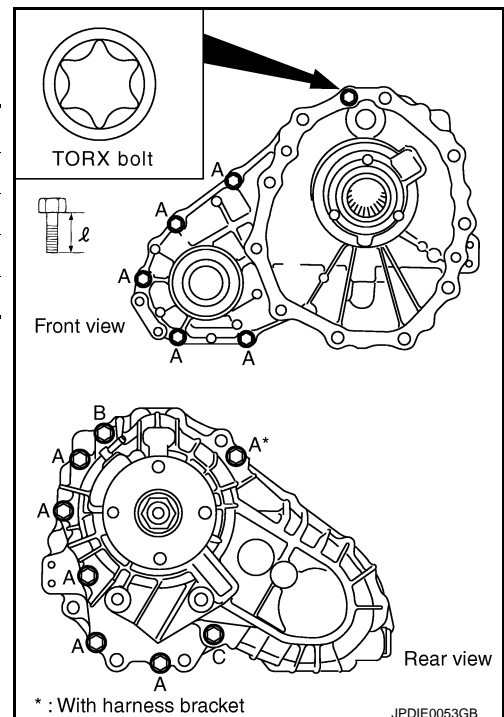

A  
B  
C  
TF  
E  
F  
G  
H  
I  
J  
K  
L  
M  
N  
O  
P

# TRANSFER ASSEMBLY

## < SERVICE INFORMATION >

10. Separate front case and rear case. Then, remove front case by levering it up with a tire lever or the like.

**CAUTION:**

**Be careful not to damage the mating surface.**

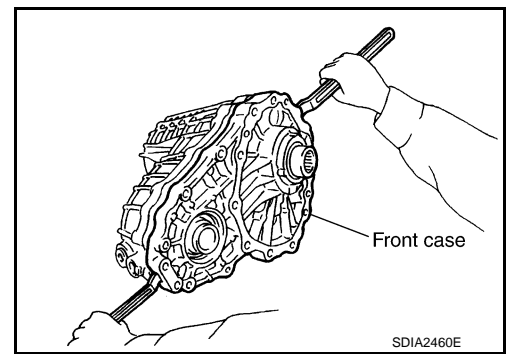

11. Remove snap ring from front case.

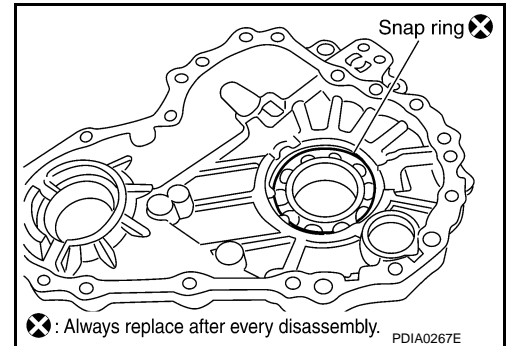

12. Remove mainshaft bearing from front case, using the drift.

**Tool number : KV38100300 (J-25523)**

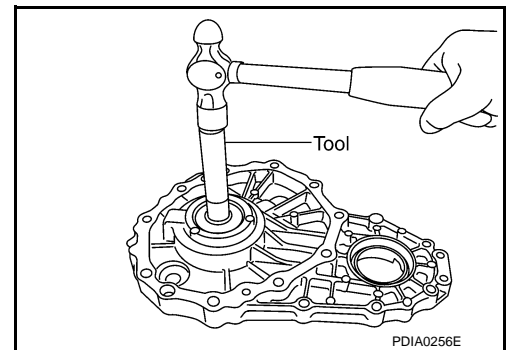

13. Remove drive chain and front drive shaft while tapping front drive shaft with plastic hammer.

**CAUTION:**

**Be careful not to tap drive chain.**

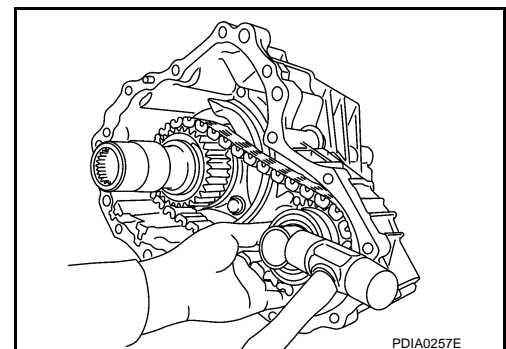

14. Remove oil gutter from rear case.

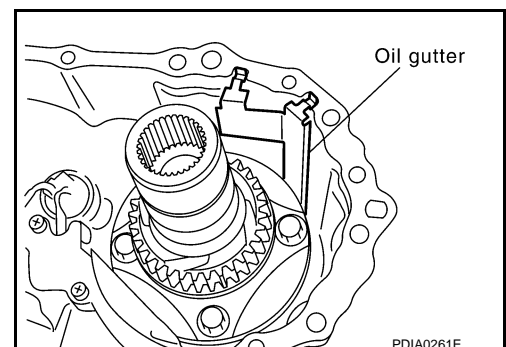

# TRANSFER ASSEMBLY

## < SERVICE INFORMATION >

15. Remove oil cover bolts from rear case. And then, remove oil cover (1).

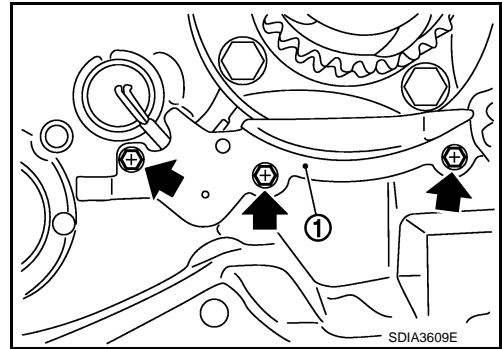

16. Remove retainer from transfer assembly harness connector.  
 17. Remove transfer assembly harness connector from rear case.  
 18. Remove O-ring from transfer assembly harness connector.

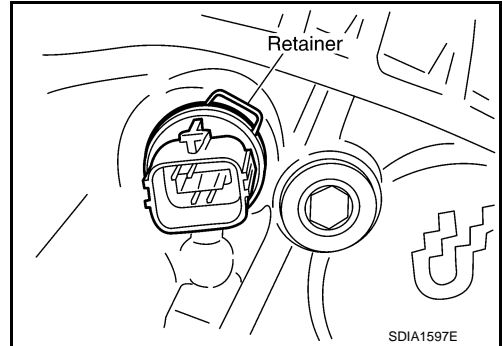

19. Remove mainshaft assembly from rear case, using the drift.

**Tool number : ST33052000 ( — )**

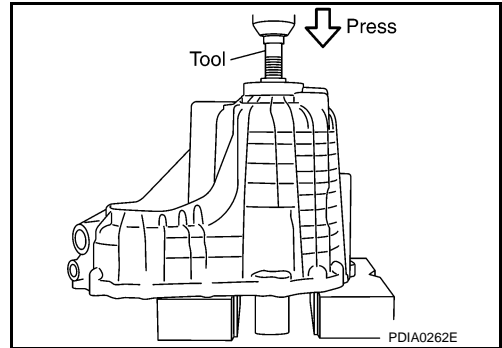

20. Remove snap ring from rear case.

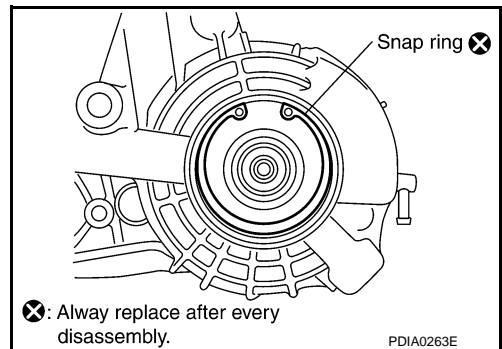

21. Remove rear bearing from rear case, using the drifts.

**Tool number A: ST30611000 (J-25742-1)**  
**Tool number B: ST35321000 ( — )**

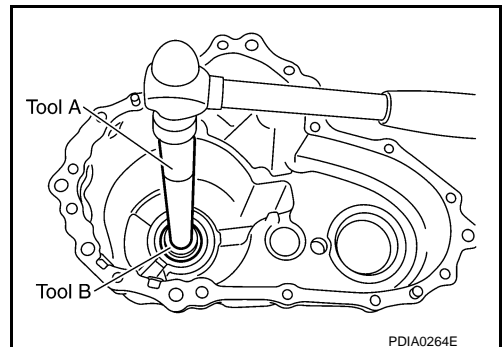

A  
B  
C  
TF  
E  
F  
G  
H  
I  
J  
K  
L  
M  
N  
O  
P

# TRANSFER ASSEMBLY

## < SERVICE INFORMATION >

22. Remove baffle plate from rear case.
23. Remove breather tube from rear case.

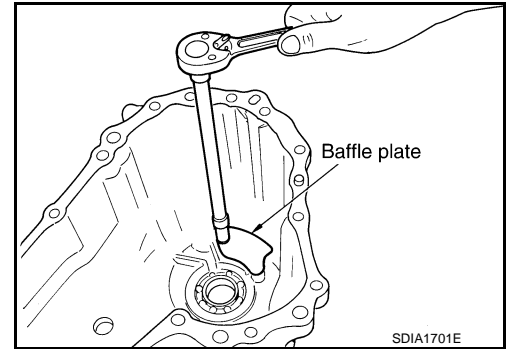

### Mainshaft Assembly

1. Separate front case and rear case, then remove mainshaft assembly. Refer to "Front case and rear case".
2. Remove snap ring from mainshaft.
3. Remove spacer from mainshaft.
4. Remove electric controlled coupling and sprocket from mainshaft.
5. Remove needle bearing from mainshaft.

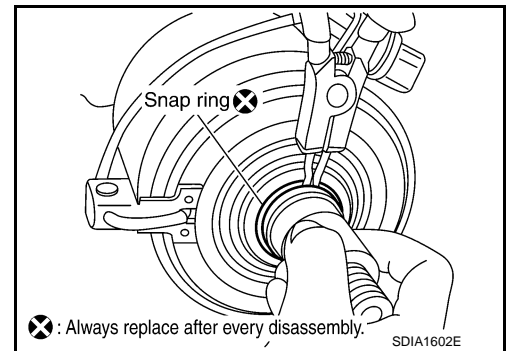

### Front Drive Shaft and Drive Chain

1. Separate front case and rear case. Refer to "Front case and rear case".
2. Remove drive chain and front drive shaft while tapping front drive shaft with plastic hammer.

#### **CAUTION:**

**Be careful not to tap drive chain.**

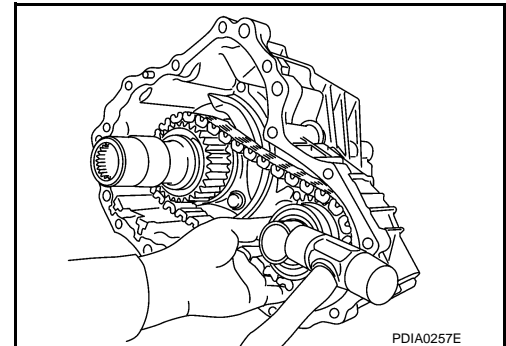

3. Remove front drive shaft front bearing, using the drift and puller.

**Tool number** : **ST31214000 (J-25269-B)**

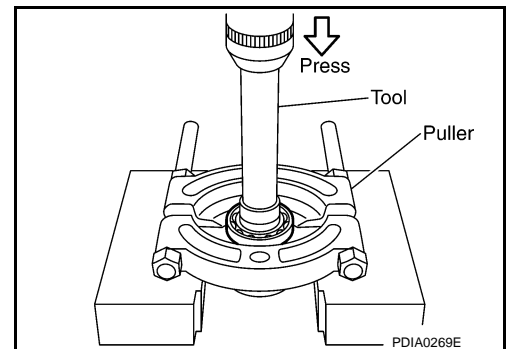



# TRANSFER ASSEMBLY

## < SERVICE INFORMATION >

4. Remove front drive shaft rear bearing, using the drift and puller.

**Tool number : ST31214000 (J-25269-B)**

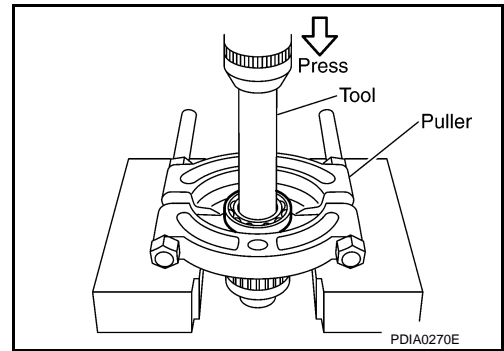

## INSPECTION

### Cases

Check items below. If necessary, replace them with new ones.

- Contact surfaces of bearing for wear, damage, etc.
- Damage and cracks of case.

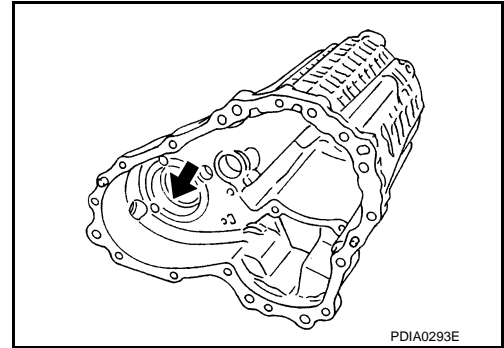

### Bearing

Check items below. If necessary, replace them with new ones.

- Damage and rough rotation of bearing.

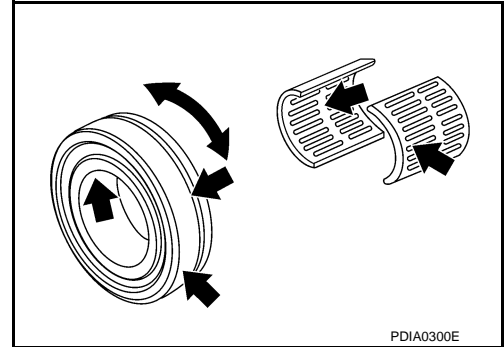

### Shaft

Check items below. If necessary, replace them with new one.

- Damage, peeling, dent, uneven wear, bending, etc. of shaft.

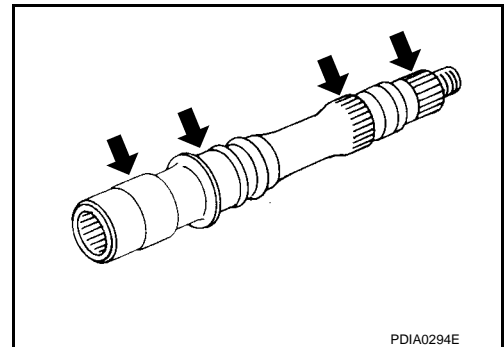

### Gears and Chain

A  
B  
C  
TF  
E  
F  
G  
H  
I  
J  
K  
L  
M  
N  
O  
P

# TRANSFER ASSEMBLY

## < SERVICE INFORMATION >

Check items below. If necessary, replace them with new ones.

- Excessive wear, damage, peeling, etc. of gear and chain.

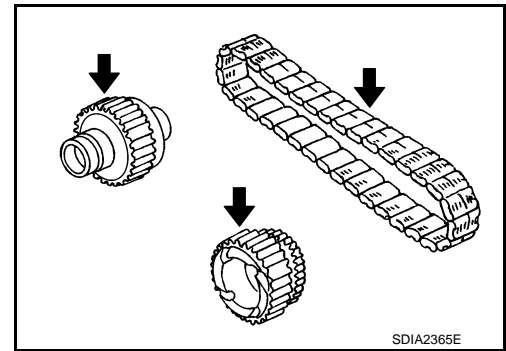

## ASSEMBLY

Front Drive Shaft and Drive Chain

1. Install front drive shaft front bearing, using the drift.

**Tool number** : ST33200000 (J-26082)

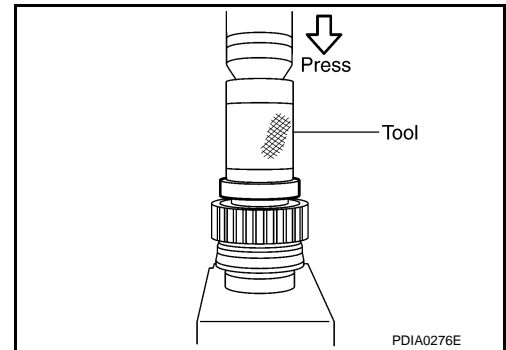

2. Install front drive shaft rear bearing, using the drift.

**Tool number** : KV38104010 ( — )

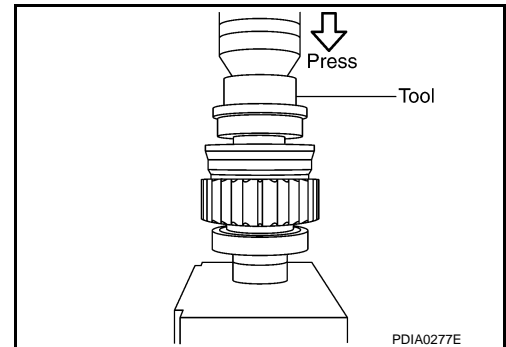

3. Install drive chain to front drive shaft.

**CAUTION:**

Identification mark of drive chain should be in the side of front bearing of front drive shaft.

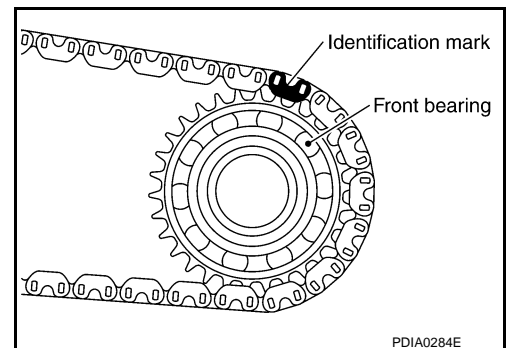

# TRANSFER ASSEMBLY

## < SERVICE INFORMATION >

4. Install drive chain to mainshaft, and then install tap front drive shaft with plastic hammer. Press-fit rear bearing of front drive shaft to rear case.

**CAUTION:**

**Be careful not to tap drive chain.**

5. Install front case to rear case. Refer to "Front case and rear case".

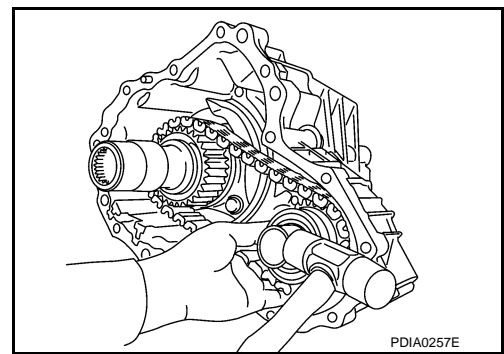

### Mainshaft Assembly

1. Install needle bearing to mainshaft.

**CAUTION:**

**Apply ATF to periphery of needle bearing.**

2. Install sprocket and electric controlled coupling to mainshaft.
3. Install spacer to main shaft.

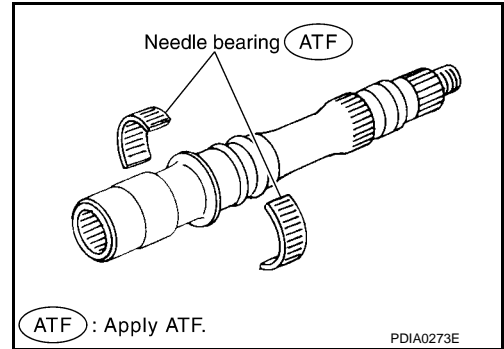

4. Install snap ring to mainshaft.

**CAUTION:**

**Do not reuse snap ring.**

5. Install mainshaft assembly to rear case, then install front case and rear case. Refer to "Front case and rear case".

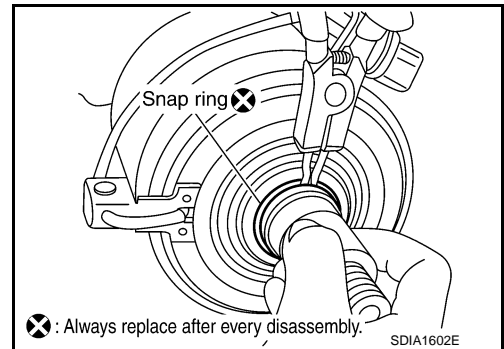

### Front Case and Rear Case

1. Install breather tube, with plastic hammer.

**CAUTION:**

**Pay attention to the direction of breather tube.**

2. Install baffle plate to rear case, and tighten bolt to the specified torque. Refer to "COMPONENTS".

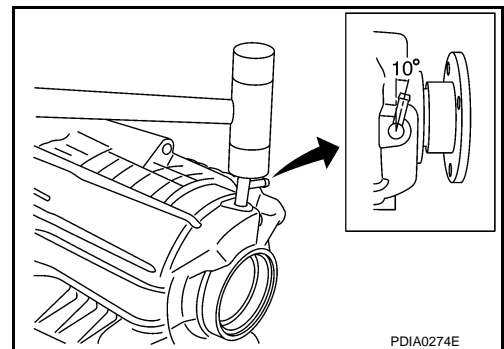

A  
B  
C  
TF  
E  
F  
G  
H  
I  
J  
K  
L  
M  
N  
O  
P

# TRANSFER ASSEMBLY

## < SERVICE INFORMATION >

3. Install rear bearing to rear case, using the drift.

**Tool number** : KV38104010 ( — )

**CAUTION:**  
Apply ATF to inside of rear bearing.

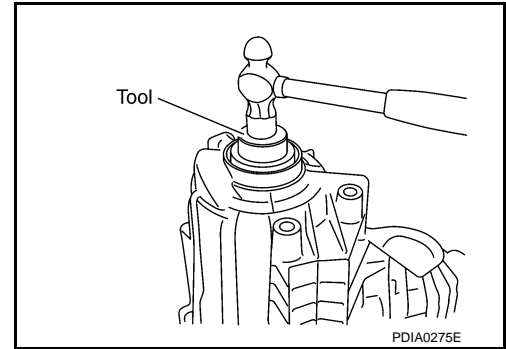

4. Install snap ring to rear case.

**CAUTION:**  
Do not reuse snap ring.

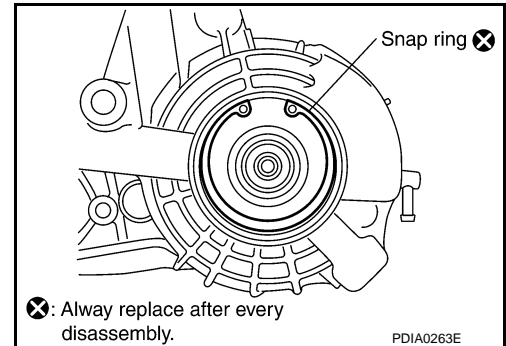

5. Install mainshaft assembly to rear case, using the drift.

**Tool number** : ST35321000 ( — )

**CAUTION:**  
ATF should be applied to contact surface of mainshaft and rear bearing.

6. Install O-ring to transfer assembly harness connector.

**CAUTION:**  
• Do not reuse O-ring.  
• Apply ATF to O-ring.

7. Install transfer assembly harness connector into rear case.

8. Install retainer to transfer assembly harness connector.

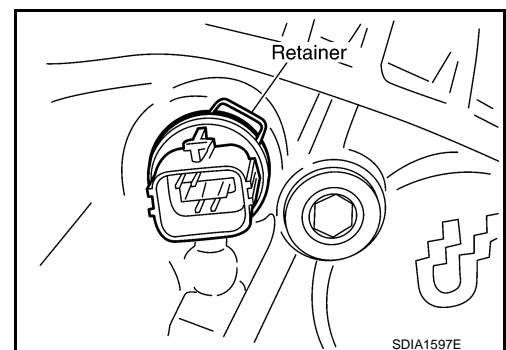
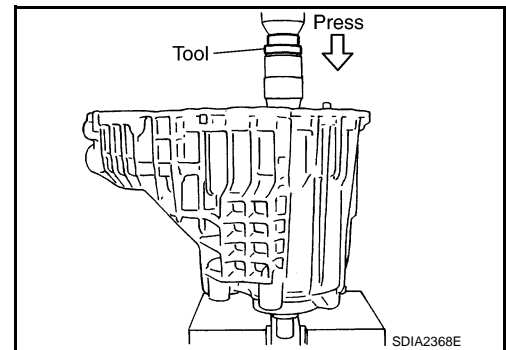

# TRANSFER ASSEMBLY

## < SERVICE INFORMATION >

9. Hold electric controlled coupling harness with oil cover hold plate, install oil cover to rear case, and tighten bolts to the specified torque. Refer to "COMPONENTS".

**CAUTION:**

The harness should be guided by a cut portion.

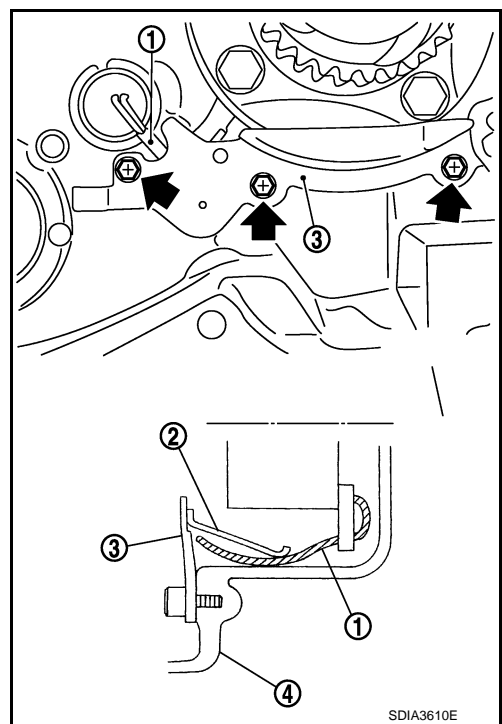

10. Install oil gutter to rear case.

**CAUTION:**

The tip of oil gutter should be put into rear case groove.

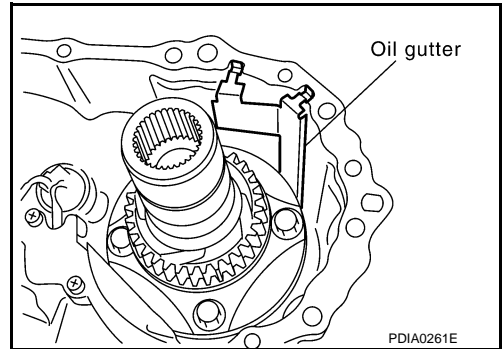

11. Install drive chain to front drive shaft.

**CAUTION:**

Identification mark of drive chain should be in the side of front bearing of front drive shaft.

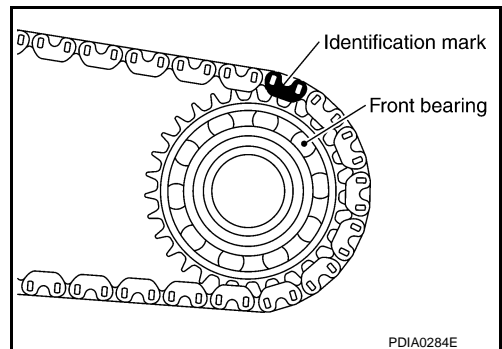

12. Install drive chain to mainshaft, and then install tap front drive shaft with plastic hammer. Press-fit rear bearing of front drive shaft to rear case.

**CAUTION:**

Be careful not to tap drive chain.

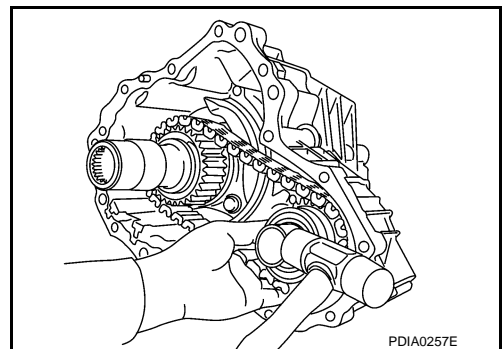

A  
B  
C  
TF  
E  
F  
G  
H  
I  
J  
K  
L  
M  
N  
O  
P

# TRANSFER ASSEMBLY

## < SERVICE INFORMATION >

13. Install mainshaft bearing to front case, using the drift.

**Tool number** : ST30621000 (J-25742-5)

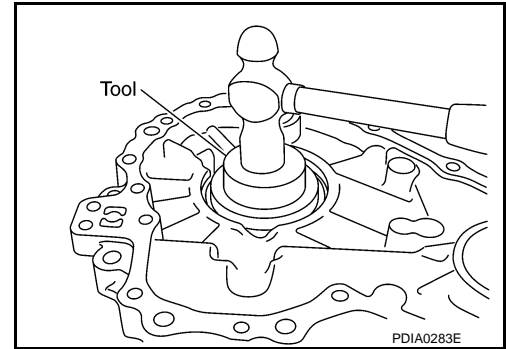

14. Install snap ring to front case.

**CAUTION:**  
Do not reuse snap ring.

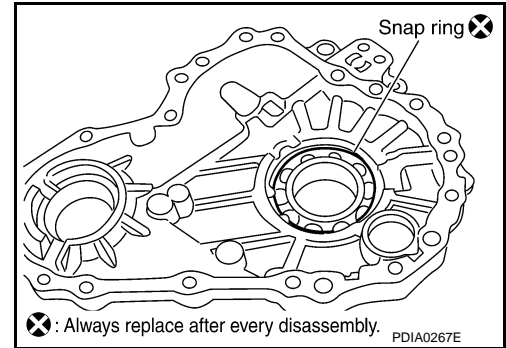

15. Apply liquid gasket to mating surface of rear case.

• Use **Genuine Anaerobic Liquid Gasket or equivalent.**  
Refer to [GI-44. "Recommended Chemical Product and Sealant"](#).

**CAUTION:**  
Remove old sealant adhering to mounting surfaces. Also remove any moisture, oil, or foreign material adhering to application and mounting surfaces.

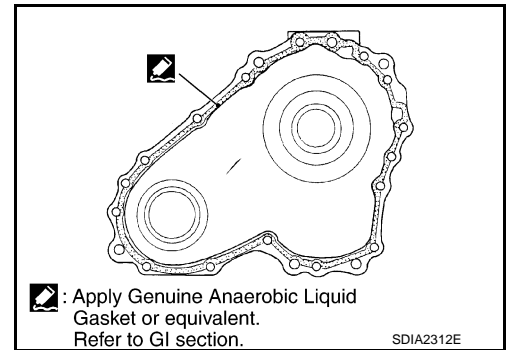

16. Set front case to rear case.

**CAUTION:**  
Be careful not to damage the mating surface transmission side.

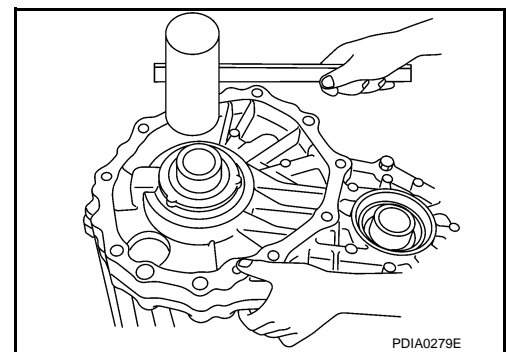

# TRANSFER ASSEMBLY

## < SERVICE INFORMATION >

17. Tighten front case and rear case fixing bolts to the specified torque. Refer to "COMPONENTS".

Bolts symbol	Quantity	Bolt length "ℓ" mm (in)
A	11	42 (1.65)
B	1	162 (6.38)
C	1	97 (3.82)
TORX bolt	1	40 (1.57)

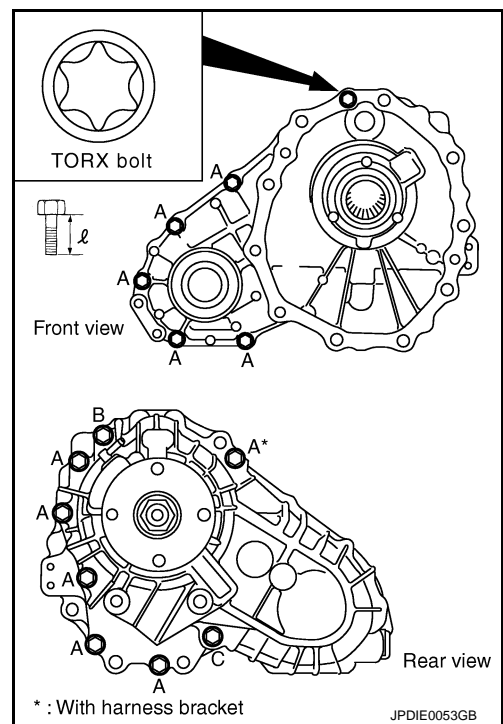

18. Install spacer to mainshaft.

**CAUTION:**  
Apply ATF to spacer.

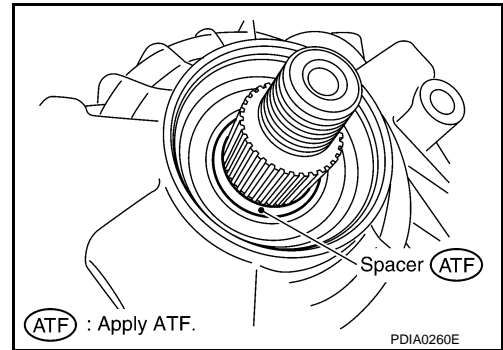

19. Install rear oil seal to rear case, using the drifts.

**Dimension A** : 6.7 - 7.3 mm (0.264 - 0.287 in)

**Tool number** A: ST30720000 (J-25405)  
B: KV40104830 ( — )

**CAUTION:**

- Do not reuse rear oil seal.
- Apply ATF to rear oil seal.
- When installing, do not incline rear oil seal.

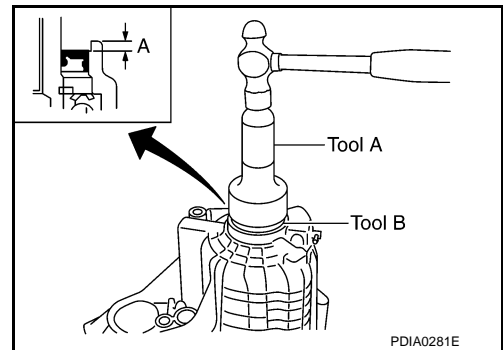

20. Install companion flange while align the matching mark of mainshaft with the mark of companion flange.

**NOTE:**  
The figure shows VQ35DE models.

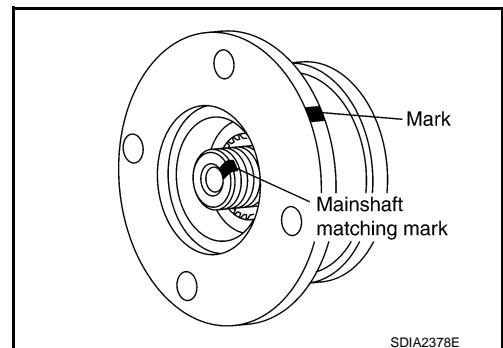

## TRANSFER ASSEMBLY

### < SERVICE INFORMATION >

21. Tighten self-lock nut to the specified torque, with flange wrench. Refer to "COMPONENTS".

**CAUTION:**

**Do not reuse self-lock nut.**

**NOTE:**

The figure shows VQ35DE models.

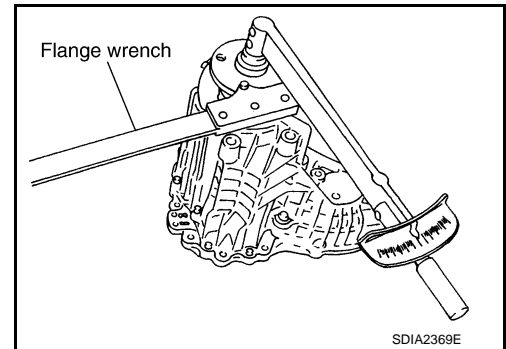

22. Install mainshaft oil seal until it is flush with end face of front case, using the drift.

**Tool number : ST30720000 (J-25405)**

**CAUTION:**

- Do not reuse mainshaft oil seal.
- Apply ATF to mainshaft oil seal.
- When installing, do not incline mainshaft oil seal.

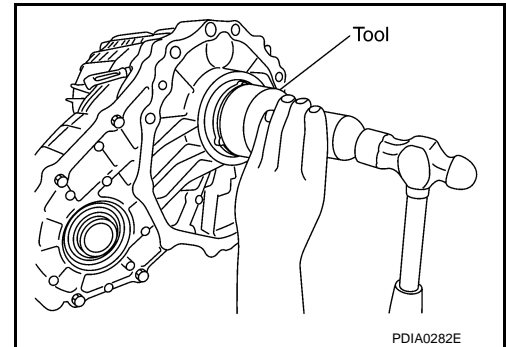

23. Install front oil seal until it is flush with end face of front case, using the drift.

**Tool number : ST27862000 ( — )**

**CAUTION:**

- Do not reuse front oil seal.
- Apply ATF to front oil seal.
- When installing, do not incline front oil seal.

24. Apply sealant to threads of drain plug. Then install it to rear case and tighten to the specified torque. Refer to "COMPONENTS".

- Use **Genuine Silicone RTV or equivalent. Refer to [GI-44](#), "[Recommended Chemical Product and Sealant](#)".**

**CAUTION:**

**Remove old sealant and oil adhering to threads.**

25. Set gasket to filler plug. Install it to rear case and tighten to the specified torque. Refer to "COMPONENTS".

**CAUTION:**

- Do not reuse gasket.
- After oil is filled, tighten filler plug to specified torque.

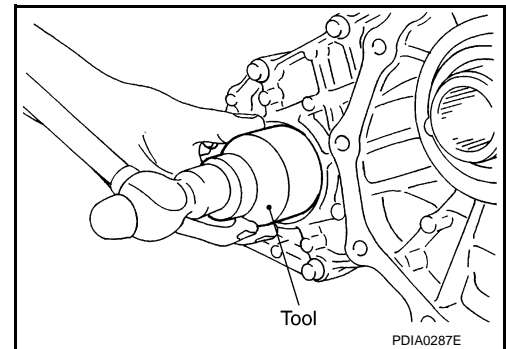



# SERVICE DATA AND SPECIFICATIONS (SDS)

< SERVICE INFORMATION >

## SERVICE DATA AND SPECIFICATIONS (SDS)

### General Specification

INFOID:000000002955711

Applied model	VQ35DE	VK45DE
Transfer model	ETX13B	
Fluid capacity (Approx.)	1.25 ℓ (2-5/8 US pt, 2-1/4 Imp pt)	

A

B

C

TF

E

F

G

H

I

J

K

L

M

N

O

P